

SELSATTM
TRAVELER KIT

I DO IT CO., LTD.

#637, Smart-Hub Industry-University Convergence Center, 237 Sangjidaehak-ro, Siheung-si, Gyeonggi-do, Korea (15073)

TEL +82 (0)31 8041 1500

FAX +82 (0)31 8041 1550

E-MAIL sales@selfsat.com

WEB www.selfsat.com

SELSATTM
TRAVELER KIT



User's manual
Bedienungsanleitung
Manuel d'utilisation

ver 2.0

www.selfsat.com

ENGLISH

DEUTSCH

FRENCH

Contents

What is SELFSAT-Traveler Kit?

What is SELFSAT-Traveler Kit?	2
-------------------------------------	---

Safety Instructions

Safety Instructions	2
---------------------------	---

Box Content

Box Content	3
-------------------	---

How to Install?

How to Install?	4
-----------------------	---

Step 1 : Where to Install?	4
----------------------------------	---

Step 2 : Check Information	5
----------------------------------	---

Step 3 : Assembly Instruction	5
-------------------------------------	---

A) Assembling the Multi-Functional Base	5
---	---

B) Installing and fixing the base of the camping set	7
--	---

C) Adjusting azimuth and elevation	12
--	----

Step 4 : Connecting the Antenna and the Set top box	13
---	----

A) How to prepare the cable?	13
------------------------------------	----

B) How to connect the cable to the antenna and the set top box?	13
---	----

Step 5 : Fine Tuning and Fix the Bracket	14
--	----

Troubleshooting Check List for Initial Installation

Troubleshooting Check List for Initial Installation	15
---	----

Loss of Signal / Rain Fade

Loss of Signal / Rain Fade	15
----------------------------------	----

What is SELFSAT-Traveler Kit ?

SELSAT Traveler Kit is

the most focused on portability that is born after the combination of SELFSAT antenna, which already has been proved the high efficiency by using horn array wave guide technology, and brand new portable bracket which is efficient and has various usage.

SELSAT antenna is using Horn array wave guide technology that can receive major satellite broadcast replacing dish shaped parabola antenna, can install easily and has high efficiency for its size.

Also the brand new portable bracket has innovative design which allow many type of install position, such as stand type, window type etc. that is able to counteract diverse install surroundings flexibly.

This combination of SELFSAT & bracket will be new paradigm.













Safety Instructions

- Before using this product please read this manual carefully and follow exactly all installation, mounting & orientation instructions.
- All the instructions should be followed in order to avoid any technical problems.
- Any electric or magnetic field close to the SELFSAT-Traveler Kit may cause a bad reception or even cut off the signal completely.
- Do not drill the plastic cover of the antenna, which seals the antenna from moisture.
- Handle the antenna with care as any impact will cause damage to the electronics.
- Do not open the cover, any attempt to repair by a non-qualified person can be dangerous and void the warranty.
- Any obstacle (buildings, trees, etc....) will block the reception of the signal from the satellite to the antenna.
- Do not paint or add any substance on the antenna cover, this will block the reception of the signal from the satellite.
- The cable between the antenna and the Satellite receiver should not exceed 30m as it will decrease the quality of the signal.
- The use non- isolated jacks will result in a loss of the signal level.
- Tighten all the screws of the antenna once you have finished the adjustments.
- This product contains one universal LNB, it is forbidden to add, change or modify the LNB.
- For more precise details on the above points or for any information, please ask your retailer or customer service.

Warning

Antennas improperly installed or installed to an inadequate structure are very susceptible to wind damage. This damage can be very serious or even life threatening. The owner and installer assumes full responsibility that the installation is structurally sound to support all loads (weight, wind & ice) and properly sealed against leaks. The manufacturer will not accept liability for any damage caused by a satellite system due to the many unknown variable applications.

Contents

No	Symbol	Part name	Image	Quantity
1	A1	Antenna Body (Antenna, Angle Bracket)		1
2	B1	Multi-Functional Base		1
3	B2	Suction cup		1
4	B4	Fix Plate		1
5	B5	Manual		1
6	B6	Carrying case		1
7	C1	Compass		1
8	S1	L type bolt		1
9	S2	U type bolt		1
10	S3	M6x65 Hex		2
11	S4	M6 Knob Nuts		4
12	S5	M8 Knob Nuts		1

How to Install?

By following the instructions step by step, you can proceed easily to install SELFSAT-Traveler Kit by yourself or with the help of a professional antenna installer.

Before installing your antenna, you check that SELFSAT-Traveler Kit box contains all the items listed above in the 'Box Content'. In the event of any missing parts, please contact your distributor.

Step 1: Where to Install?

In order to receive a signal from the Satellite, SELFSAT-Traveler Kit is to be installed in an open loop space (outside the house or the apartment), in the direction of the satellite towards the equator, for which, you will need a compass to exactly orient SELFSAT-Traveler Kit toward the satellite.

Note

please take reference to the table of the Azimuth angles specified in the back pages of this manual.



< Compass >

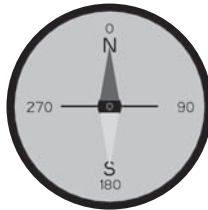

< Azimuth Angle >

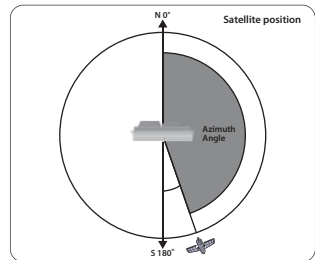

Note

To ensure an accurate compass reading, stay away from large metal objects, specifically electrical cables and then make multiple readings.

Make sure that there are no obstacles in front of SELFSAT-Traveler Kit which can decrease the signal reception quality, such as buildings or trees (you may keep in mind that trees will grow and may block the signal).

In order to be able to fix and install your antenna easily, you might choose an easily accessible place without any potential danger for installation.

Think about the way you might pass your cable in a discreet way from the SELFSAT-Traveler Kit to your Set top Box. The antenna should not be too distant from your satellite receiver; a cable longer than 30 meters may decrease the quality of the signal.

Bad Quality Signal Reception

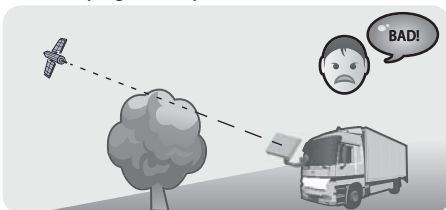

Good Quality Signal Reception

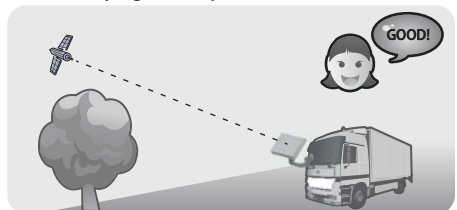

Step 2: Check Information

In order to install antenna, you need to find skew, elevation and azimuth angle by referring the table on the back of the manual. If you can't find your location, please refer to the information of the nearest place from your location. This manual will show you the installation example to receive ASTRA1 satellite in Brest region of France. The angle information for Brest region is Skew : -19.7, El : 30, Az : 149.6

Step 3 : Assembly Instruction

A) Assembling the Multi-Functional Base

- 1) Open the Multi-Functional Base
- Open the two wings of the Multi-Functional

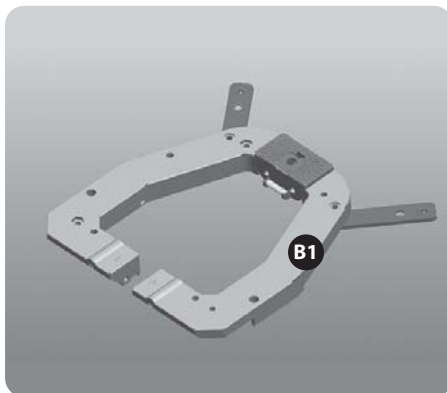
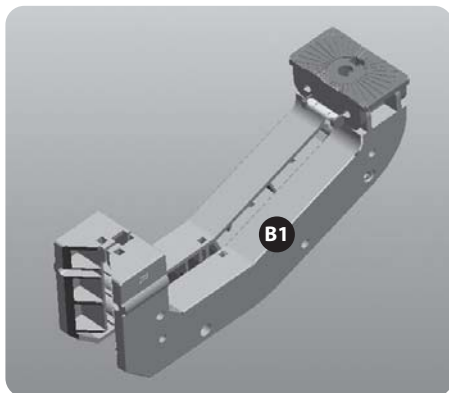

- Pull out the Base Support, then put it on the plane

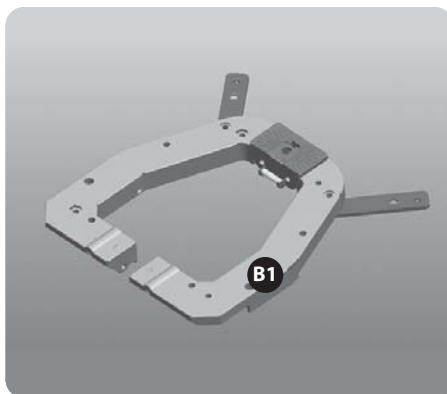
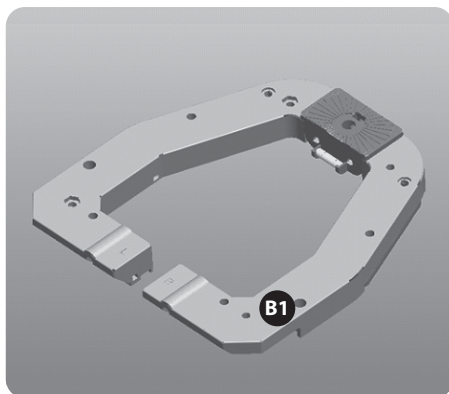

2) Fold the Multi-Functional Base

- Use the two M6x65mm Hex. Head Screws and two M6 Knob Nuts to fasten the Multi-Functional Base

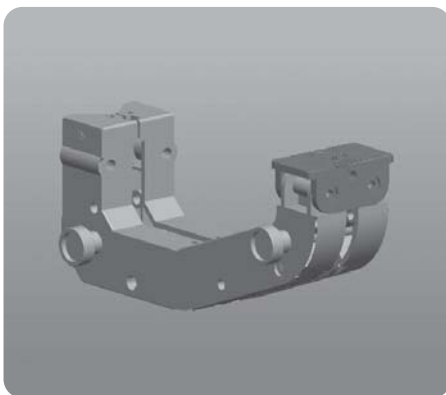
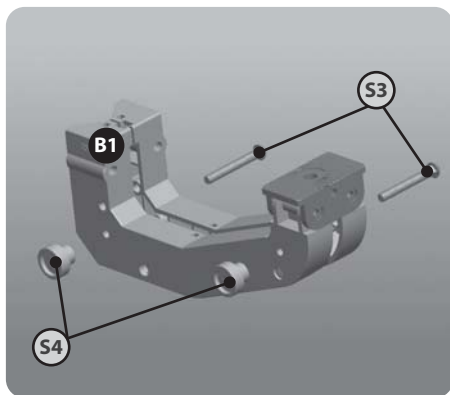

B) Installing and fixing the base of the camping set

Type 1

- 1) Take the folded Multi-Functional Base on the table
- 2) Put the long side of L-Type Bolt into the Fix Plate and the short side into the Multi-Functional Base

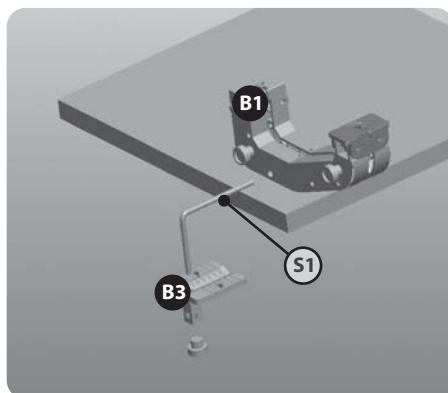

- 3) Use the M8 Knob Nut to fasten the Fix Plate and the Multi-Functional Base
- 4) Insert the Antenna Set onto the Multi-Functional Base and M6x25mm Knob Screw to fasten the Camping-Set on the table

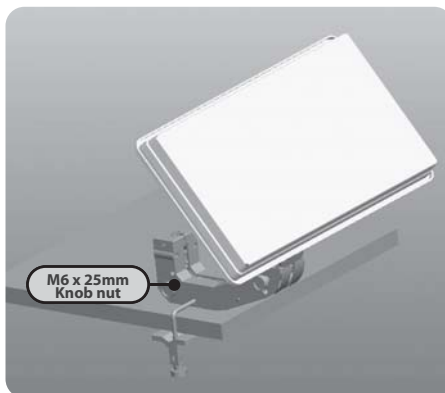
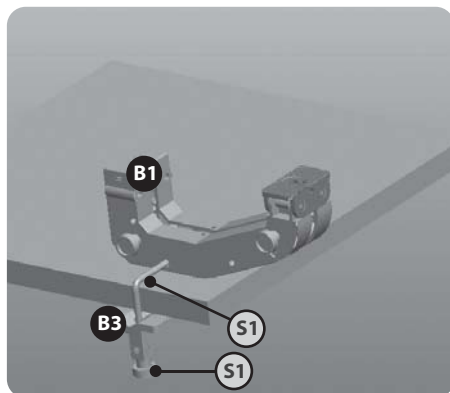

Type 2

- 1) Put the folded Multi-Function Base along a mast and insert the U-Type Bolt into the Multi-Functional Base. Then use two M6 Knob Nuts to fasten the Multi-Functional Base on the mast
- 2) Insert the Antenna Set onto the Multi-Functional Base and use M6x25mm Knob Screw to fasten the Camping-Set

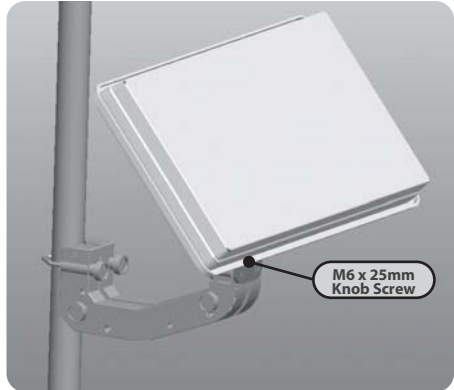
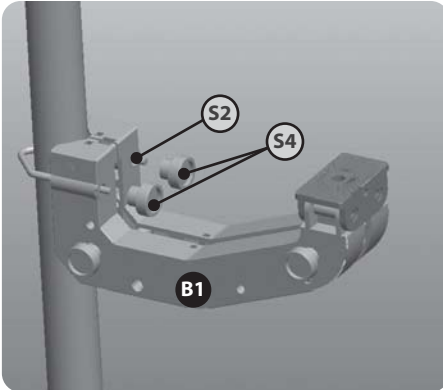

Type 3

- 1) Take the open Multi-Function Base and slightly loosen the M6x25mm Knob Screw
- 2) Insert the Antenna Set onto the opened Multi-Functional Base. Then tighten the M6x25mm Knob Screw

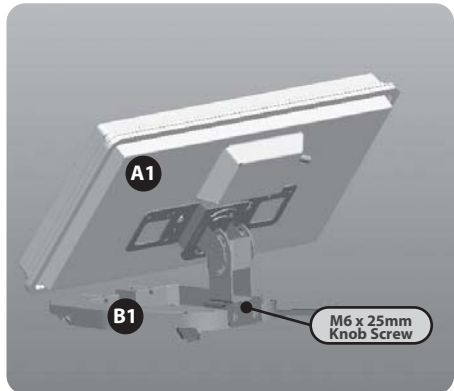
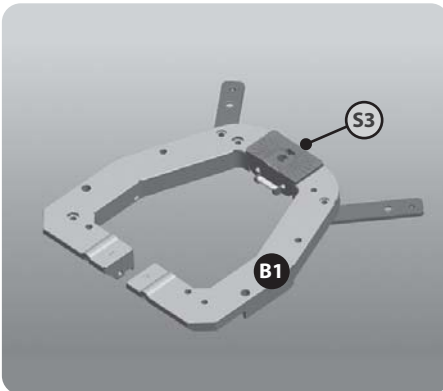

Type 4

- 1) Upright the handle of the suction cup, then push it on the plane
- 2) Press the handle of the suction cup backwards to fix the suction cup base

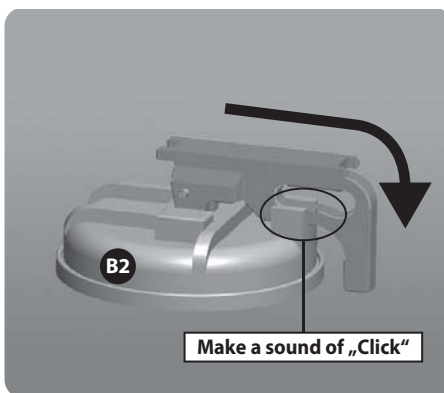
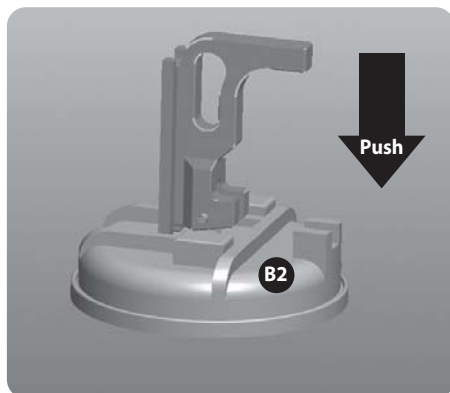

- 3) Lightly loosen the M6 Knob Nut, then slide the folded Multi-Functional Base into the suction cup set to the end (see red arrow below)

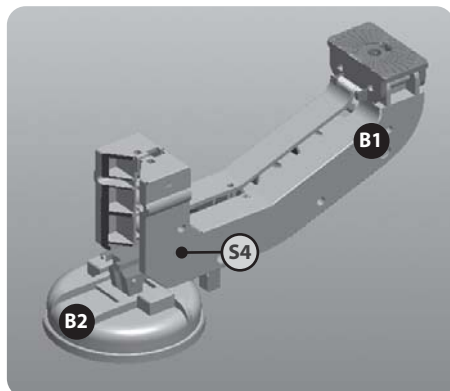
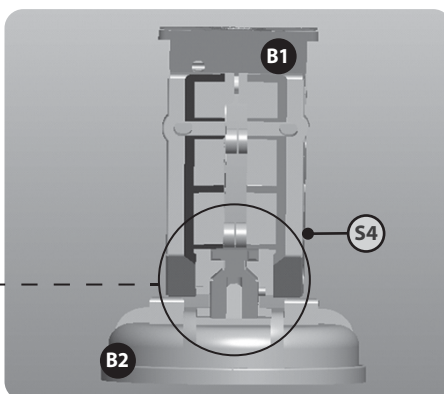
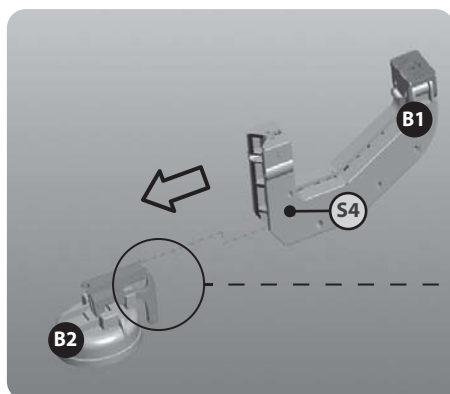

- 4) Insert the Antenna Set onto the Multi-Functional Base and use M6x25mm Knob Screw to fasten the Camping-Set

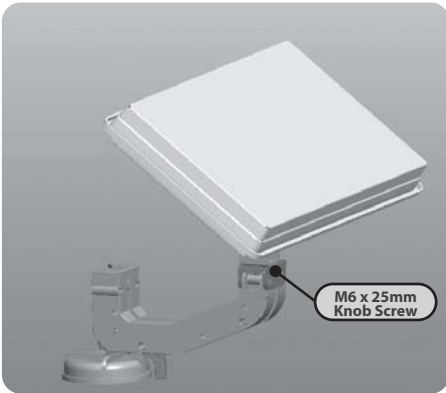

Type 5

- 1) Upright the handle of the suction cup, then push it on the plane
- 2) Press the handle of the suction cup backwards to fix the suction cup base

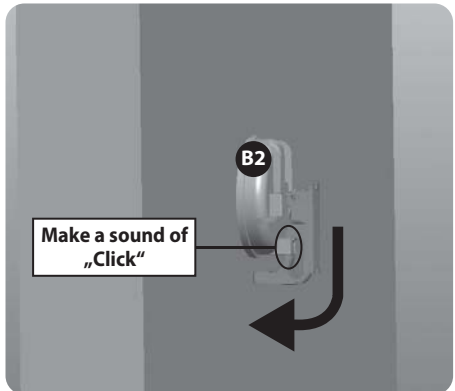
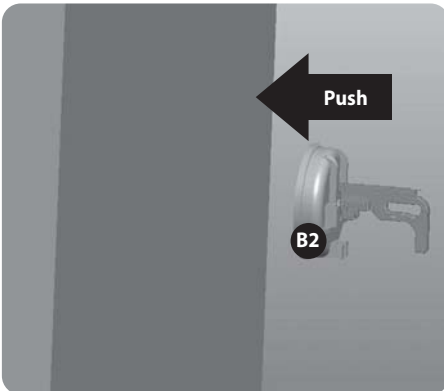

- 3) Slightly loosen the M6 Knob Nut
- 4) Slide the folded Multi-Functional Base into the suction cup set to the end (see red arrow below)

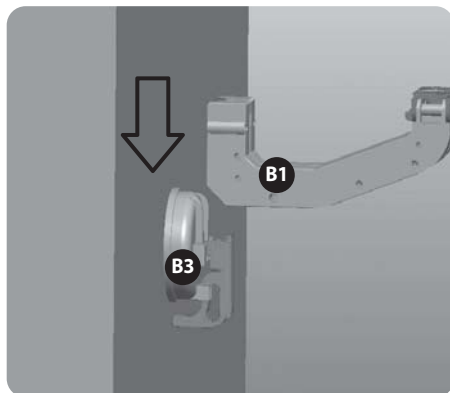

- 5) Tighten the M6 Knob Nut to fasten the Multi-Functional Base on the suction cup
- 6) Insert the Antenna Set onto the Multi-Functional Base and tighten the M6x25mm Knob Screw

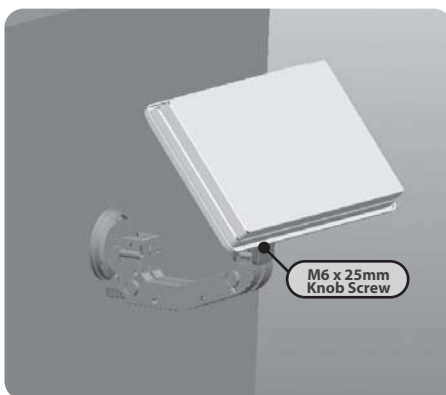
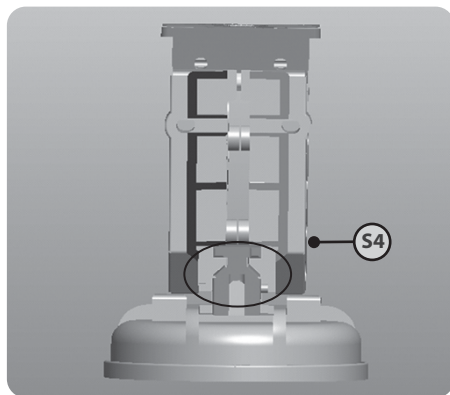

C) Adjusting angle (skew, elevation, azimuth)

Adjusting the skew

Refer to the Angle Table, set the exact angle, then tighten up with M6x18mm bolt. Skew angle is an important factor to get optimized signal.

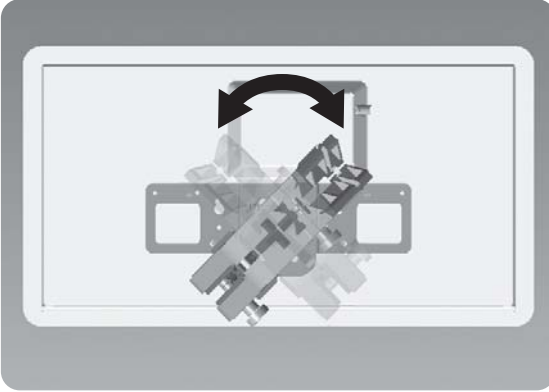

Adjusting the elevation

Refer to the Angle Table, set the local elevation angle.

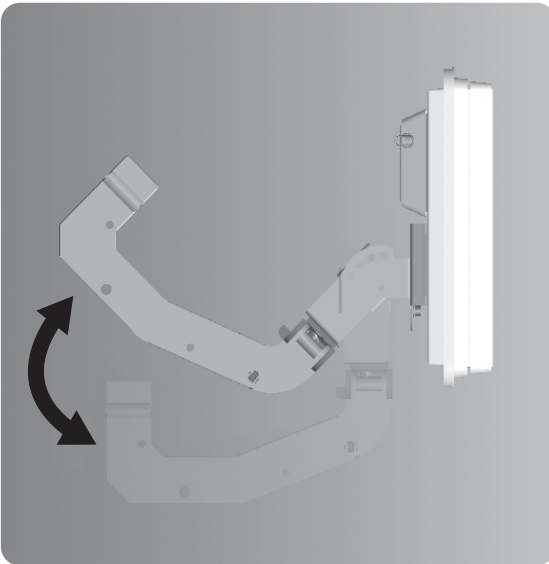

Adjusting the azimuth

Check the broadcast is showing while adjusting antenna.

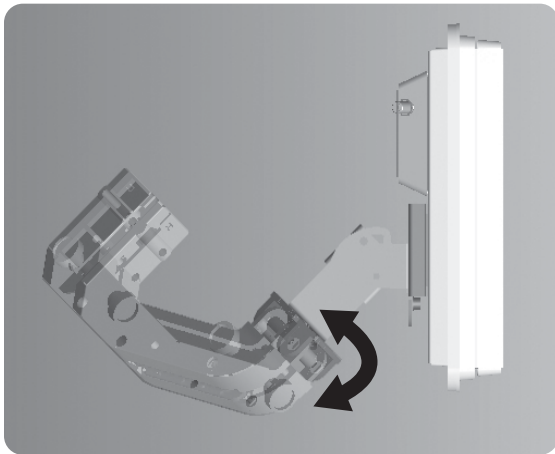

Find the optimized elevation & azimuth angle, then tighten up with bolt.

Step 4 : Connecting the Antenna and the Set top box

Once you have installed the antenna in an open loop space and mounted the way you want it to be the next step is to connect it all together.

In order to be able to watch your favorite satellite programs, you need to connect your satellite antenna to a receiver by a cable. The cable between the antenna and the Satellite receiver should not exceed 30m as it will decrease the quality of the signal. The use of a long or bad quality cable and not isolated jacks can cause a loss of the signal level, it would be preferable to use an RG6 Coaxial cable (HF 17VATC or 19VATC cable), in order to minimize a signal loss.

A) How to prepare the cable?

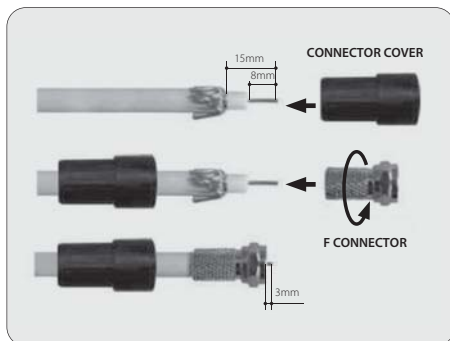

B) How to connect the cable to the antenna and the set top box?

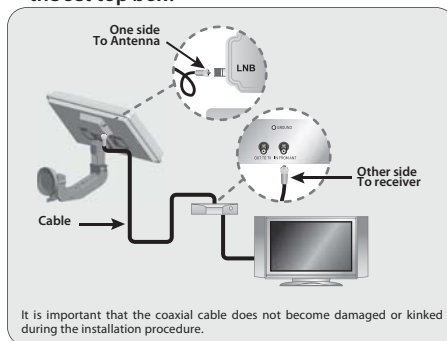

Step 5 : Fine Tuning and Fix the Bracket

Once fine tuning is completed for signal reception, please tighten bolt and nut.

Once all connected, turn on the TV and the Satellite receiver.

Select the Antenna Pointing Menu on your set top box.

You can check signal level on your TV.

Do not forget to choose "LNB : ON"

You will need someone to stay in front of the TV to tell you when the signal is "good" while you're outside trying to adjust the antenna the best way possible.

The signal level and quality is indicated on the TV screen and will fluctuate and change color according to the adjustment & movement of the antenna while you are pointing & finding (azimuth, elevation angle).

The level indicates the power of the signal and the color is the signal reception quality from the chosen satellite.

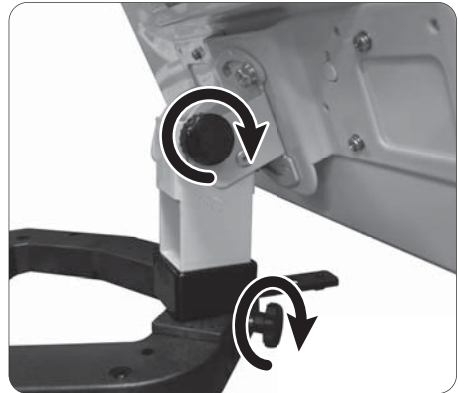
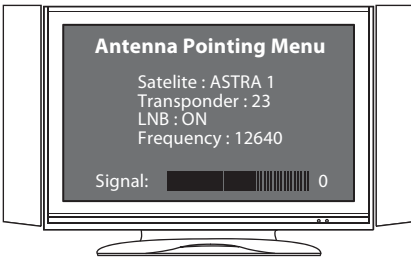

Troubleshooting Check List for Initial Installation

If the signal is not found, be sure the receiver user manual and the antenna user manual have been followed closely, check the following:

- Make sure all cable connections are correct and each connection is seated / tightened properly
- Inspect the inside of each cable connector for dirt or possible connector to case/shield short.
- Verify the Azimuth, Elevation and Tilt angles for your location by ZIP code.
- Make sure the Tilt and Elevation pointers are aligned correctly to the scales. Do not use washer or bolt as reference.
- Make sure the Tilt adjustment is not changed from the recommended setting for the antenna location.
- Remove existing TV-specific components such as TV splitter; etc reduce the installation to the basic connections called out in this guide. Such components may not work with the satellite signal and they may be in the wall where you can't see them. When in doubt. Run RG6 cable directly to your receiver.
- Make sure there are no obstructions (trees, buildings, windows, corner or overhang of your roof, your body or hands) – the signal does not pass leaves, branches, glass, etc.
- RG 6 cable with solid copper center conductor is highly recommended because it has much lower DC voltage drop compared to RG 6 cable with a copper-coated, steel center conductor.
- Standard RG 59 cable causes too much DC drop and signal drop; it cannot be used to pass the satellite signal. RG 6 coaxial cable must be used.
- Some after-market, off-the-shelf add-on components may not be as advertised. They might not work or could cause additional DC drops and signal amplitude attenuation. Remove such components. Go back to the basic connections called out in this manual and re-verify.
- Make sure the satellite cable is connected to the "Sat In" jack, not the "Antenna In" jack, The "Antenna In" jack at the back of the receiver is for off-air antenna input or cable TV input.
- If all are done correctly but the signal is still not found. Change the Elevation adjustment of the antenna slightly ($\pm 2^\circ$, then $\pm 4^\circ$ from the called-for setting) and repeat the procedure.
- Make sure the Access Card from your receiver is fully inserted into the Access Card slot and oriented correctly.

Loss of Signal / Rain Fade

- The satellite signal may be lost temporarily due to unusually heavy rainfall. An optimally aligned antenna, along with the shortest possible cable run, minimizes the chances of "rain fade."
- Make sure the antenna is mounted securely to prevent it from being blown out of alignment in a heavy wind.
- Heavy snow accumulation on the antenna may reduce the satellite signal strength, snow should be swept away as soon as possible.
- Tree foliage growth into antenna's line-of-sight to the satellite may result in gradual loss of picture.

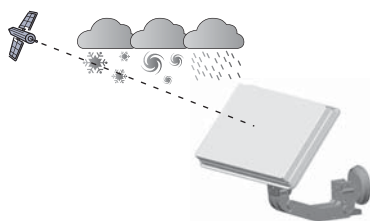

Inhalt

Was ist das SELFSAT-Traveler Kit?

Was ist das SELFSAT-Traveler Kit?	2
---	---

Sicherheitshinweise

Sicherheitshinweise	2
---------------------------	---

Verpackungsinhalt

Verpackungsinhalt	3
-------------------------	---

Installation

Installation	4
Schritt 1: Ort der Installation	4
Schritt 2: Wichtige Informationen	5
Schritt 3: Montageanleitung	5
A) Montage des Multi-Funktions-Ständers	5
B) Installation und Befestigung des Ständers	7
C) Einstellung von Skew (Drehung), Azimuth (Winkel) und Elevation (Neigung)	12
Schritt 4: Anschließen der Antenna an den Receiver	13
A) A) Vorbereitung des Kabels	13
B) B) Wie Sie das Kabel an der Antenne und den Receiver anschließen	13
Schritt 5: Feinabstimmung und Befestigung der Halterung	14

Checkliste zur Fehlerbehebung für die Erstinstallation

Checkliste zur Fehlerbehebung für die Erstinstallation	15
--	----

Signalverlust / Beeinträchtigung durch Regen

Signalverlust / Beeinträchtigung durch Regen	15
--	----

as ist das SELFSAT-Traveler Kit?

Das SELFSAT Traveler Kit ist bestens für Portabilität ausgerüstet. Die Antenne wurde mit modernster Technologie erweitert. Die tragbare Ausrüstung kann effizient eingesetzt werden und bietet mit den verschiedenen Befestigungsmethoden einen sehr hohen Komfort.

Die SELFSAT Antenne ist mit der „Horn Array Wave Guide-Technologie“ ausgestattet und ersetzt gleichwertig einen herkömmlichen Parabol-, bzw. Off-Set-Spiegel. Sie ist leicht zu installieren und erzielt einen sehr hohen Wirkungsgrad.

Auch der neue tragbare Standfuß besitzt ein innovatives Design, das viele Arten der Installation zulässt. Befestigen Sie die Antenne wie gewohnt, am Fenster, oder ähnliches. Damit sind Sie in der Lage sich Ihrer Umgebung anzupassen und flexibel entgegenzuwirken.

Die Kombination aus SELFSAT und Halterung wird ein neues Paradigma sein.













Sicherheitshinweise

- Vor der Verwendung dieses Produkts lesen Sie bitte diese Bedienungsanleitung sorgfältig durch und befolgen Sie die Installations-, Montage- und Ausrichtungsanweisungen.
- Alle Anweisungen sollten befolgt werden, um technische Probleme zu vermeiden.
- Jegliches elektrische oder magnetische Feld in der Nähe des SELFSAT-Traveler Kit kann einen schlechten Empfang oder sogar den kompletten Empfang beeinflussen.
- Bohren Sie nicht in den Kunststoffdeckel der Antenne, sie schützt die Antenne vor Feuchtigkeit.
- Behandeln Sie die Antenne vorsichtig, da jeglicher Stoß zu Schäden an der Elektronik führen kann.
- Öffnen Sie nicht die Abdeckung. Es muss eine entsprechend ausgebildete Person anwesend sein. Bei nicht autorisierten Personen erlischt die Garantie.
- Jegliches Hindernis (Gebäude, Bäume, usw.) blockiert den Empfang vom Satelliten zur Antenne.
- Nicht mit einem Stift auf die Antenne schreiben, oder sonstige Substanzen aufbringen, da diese den Empfang der Antenne beeinträchtigen.
- Das Kabel zwischen der Antenne und dem Satellitenempfänger darf nicht länger als 30 Meter sein, sonst wird das Signal immer schwächer.
- Die Verwendung von nichtisolierten Anschlüssen führt zum Verlust des Signals.
- Ziehen Sie alle Schrauben der Antenne an, wenn Sie die Anpassungen vorgenommen haben.
- Dieses Produkt enthält ein Universal-LNB. Es ist verboten, es zu ersetzen, zu ändern oder zu modifizieren.
- Für genauere Angaben über die oben genannten Punkte oder sonstige weitere Informationen, wenden Sie sich bitte an Ihren Fachhändler oder den Kundendienst.

WARNUNG!

Antennen die unsachgemäß installiert oder an einem unebenen Untergrund montiert wurden, sind sehr anfällig für Wind-Schäden. Diese Schäden können sehr ernst oder sogar lebensbedrohlich sein. Der Besitzer und Installateur übernimmt die volle Verantwortung dafür, dass die Installation fachgerecht durchgeführt worden ist und die Antenne alle Lasten wie Gewicht, Wind oder Eis standhält. Der Hersteller übernimmt keine Haftung für Schäden, die durch eine Satelliten-Anlage aufgrund der vielen unbekannt variierenden Anwendungen verursacht wurde.

Verpackungsinhalt

Nr.	Symbol	Bezeichnung	Bild	Anzahl
1	A1	Antenne (inkl. Antennenbefestigung)		1
2	B1	Multi-Funktions-Ständer		1
3	B2	Saugfuß		1
4	B4	Befestigungsplatte		1
5	B5	Bedienungsanleitung (Optional)		1
6	B6	Kunststoffkoffer		1
7	C1	Kompass		1
8	S1	L Type Schraube		1
9	S2	U Type Schraube		1
10	S3	M x 65 Sechskantschraube		2
11	S4	M6 Drehknopf		4
12	S5	M8 Drehknopf		1

Installation

Wenn Sie folgenden Schritte beachten, können Sie die Antenne (SELSAT Traveler Kit) alleine, ohne Hilfe eines professionellen Monteurs installieren.

Schritt 1: Ort der Installation?

Um mit der Antenne (SELSAT-Traveler Kit) ein Signal vom Satelliten zu empfangen, benötigen Sie freie Sicht zum Himmel (Satelliten). Die Richtung des gewünschten Satelliten können Sie mit Hilfe eines Kompass bestimmen. (in der Regel Süd-Ost) Astra 1 z.B. befindet sich auf der Orbit Position 19,2° Ost.

Hinweis

Den Höhenwinkel, der abhängig ist von Ihrem Standort, entnehmen Sie bitte aus der Tabelle auf der letzten Seite dieser Bedienungsanleitung.



< Kompass >



< Azimuth Winkel >

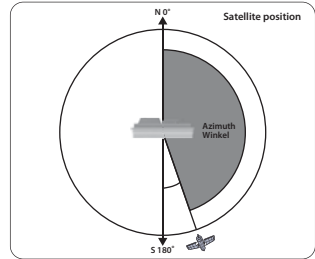

Hinweis

Um eine genaue Kompassmessung zu gewährleisten, vermeiden Sie bitte den Aufenthalt neben großen Metallgegenständen (insbesondere elektrische Leitungen) und nehmen mehrere Ablesungen vor.

Stellen Sie sicher, dass sich keine Hindernisse wie Gebäude oder Bäume vor dem SELSAT-Traveler Kit befinden, das den Empfang oder die Qualität des Signals verringern könnte. Bei einer dauerhaften Montage, beachten Sie bitte, dass Bäume oder ähnliches wachsen und dann das Signal blockieren können.

Wenn möglich installieren Sie die Antenne an einem leicht zugänglichen Ort, um evtl. Reparaturen ohne potenzielle Gefahren durchzuführen zu können.

Bei fester Montage verlegen Sie Ihr Kabel fachgerecht und auf kürzestem Weg vom SELSAT-Traveler Kit zu Ihrem Receiver. Die Antenne sollte nicht zu weit entfernt von Ihrem Satellitenempfänger stehen. Ein Kabel länger als 30 Meter, kann die Qualität des Signals verringern. Vor der Installation der Antenne, überprüfen Sie, ob die SELSAT-Traveler Kit-Box alle oben genannten Teile enthält. Im Falle fehlender Teile, wenden Sie sich bitte an Ihren Händler.

Schlechtes Signal

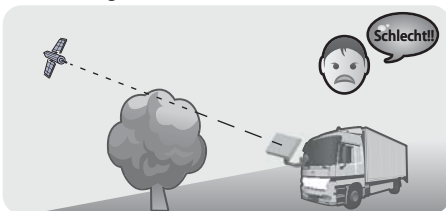

Gutes Signal

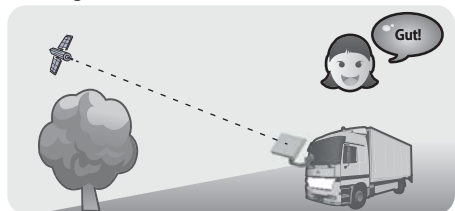

Schritt 2: Information

Um die Antenne zu installieren, müssen Sie Skew, Elevation und Azimut Winkel einstellen. Sie finden die Daten auf der Rückseite Ihres Handbuchs. Wenn Sie Ihren Standort nicht finden können, entnehmen Sie bitte die Informationen des nächstgelegenen Ortes, an dem Sie sich befinden. Dieses Handbuch zeigt Ihnen die Installation für den Satelliten ASTRA1 (19,2° Ost) in der Region Berlin in Deutschland. Die Einstellungen für die Region Berlin sind: SKEW 3,7° / Elevation: 29,7 / Azimuth: 172°; Made by Megaset

Schritt 3 : Montageanleitung

A) Montage des Multi-Funktions-Ständers

- 1) Öffnen des Multi-Funktions-Ständers
 - Öffnen Sie die beiden Flügel des Ständers

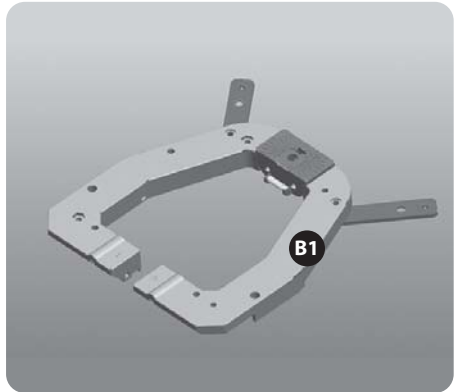
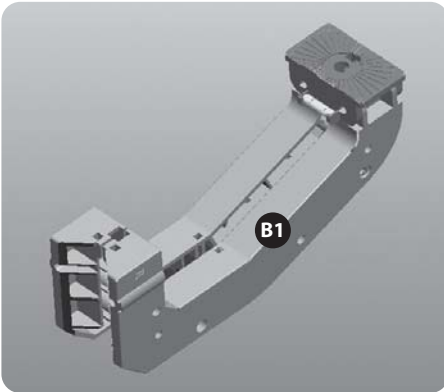

- Öffnen Sie die beiden Flügel des Ständers

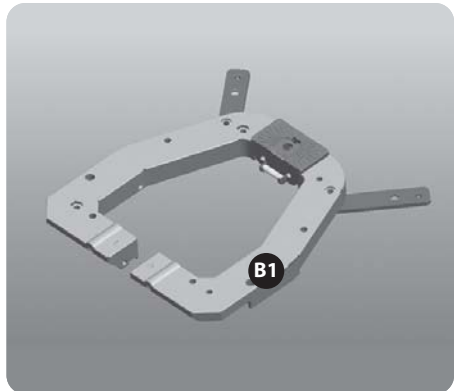
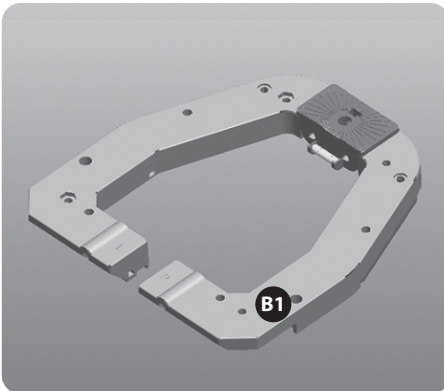

2) Falten des Multi-Funktions-Ständers

- Benutzen Sie die zwei M 6 x 65 mm Sechskantschraube, Kopfschrauben und zwei M 6 Drehknöpfe um den Ständer zu fixieren

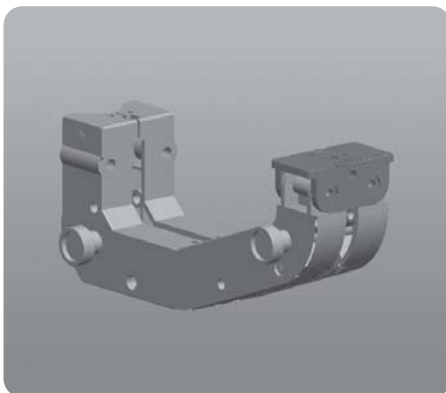
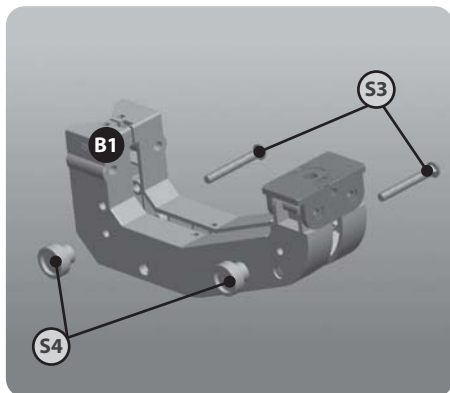

B) Installation und Befestigung des Ständers

Methode 1

- 1) Legen Sie den gefalteten Multi-Funktions-Ständer auf den Tisch
- 2) Schieben Sie die lange Seite der L-Typ Schraube in die Befestigungsplatte und die kurze Seite in den Multi-Funktions-Ständer

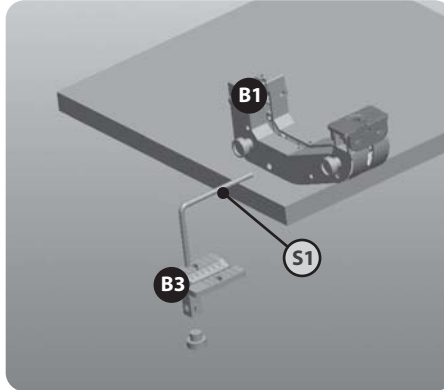

- 3) Verwenden Sie die M8 Drehknöpfe um die Befestigungsplatte und den Multi-Funktions-Ständer zu befestigen
- 4) Befestigen Sie die Antenne mit den M 6 x 25 mm Schrauben

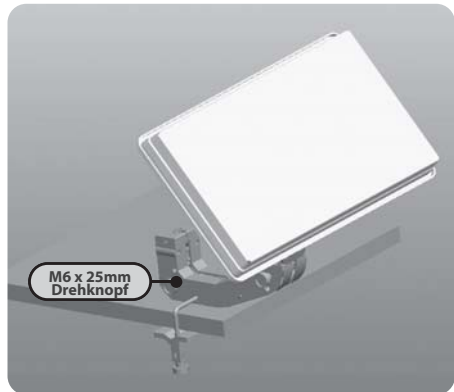
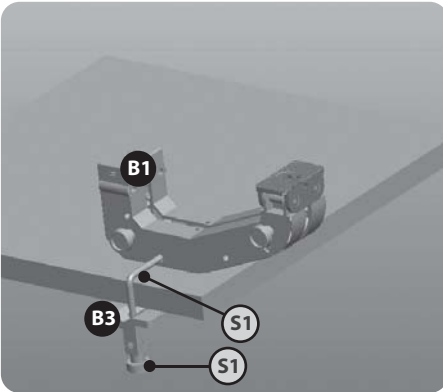

Methode 2

- 1) Legen Sie den gefalteten Multi-Funktions-Ständer an den Mast an und stecken Sie die U-Type Schraube in den Multi-Funktions-Ständer. Dann benutzen Sie zwei M 6 Drehknöpfe, um den Multi-Funktions-Ständer an dem Mast zu befestigen
- 2) Befestigen Sie die Antenne mit den M 6 x 25 mm Schrauben

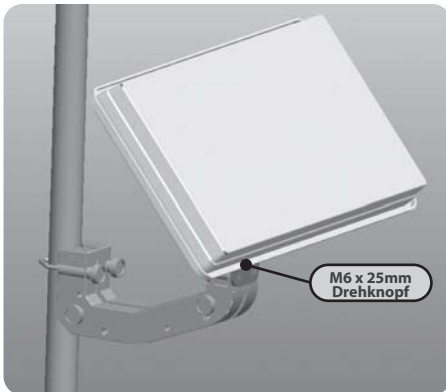
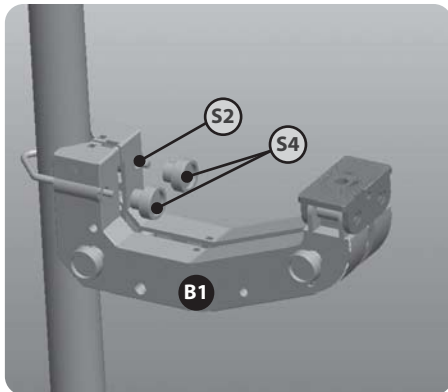

Methode 3

- 1) Nehmen sie den geöffneten Multi-Funktions-Ständer und lösen leicht die M 6 x 25 mm Feststellschraube
- 2) Legen Sie die Antenne auf den Multi-Funktions-Ständer und ziehen die Feststellschraube an

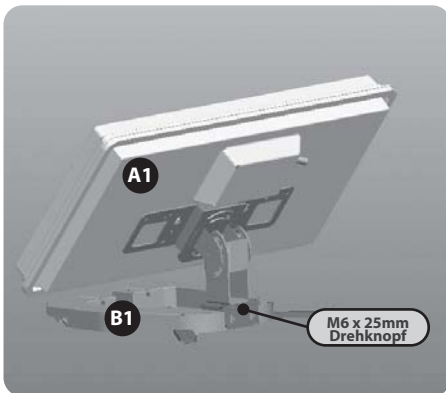
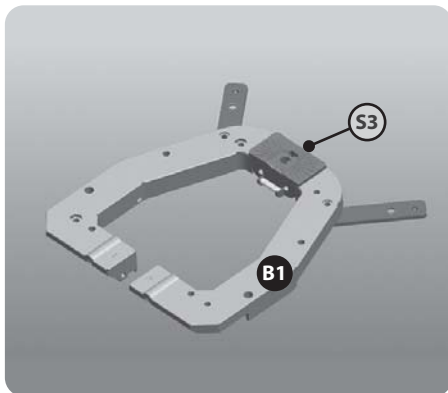

Methode 4

- 1) Legen Sie den Saugfuß mit aufrechem Hebel auf eine waagerechte glatte Oberfläche
- 2) Drücken Sie den Hebel des Saugfupes nach unten

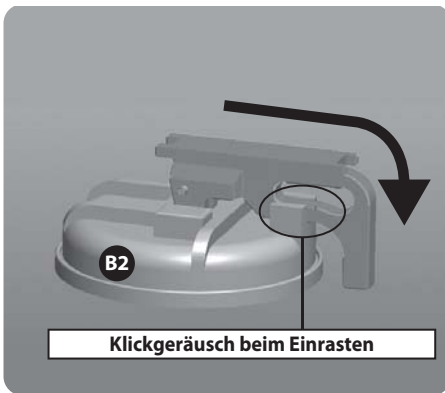
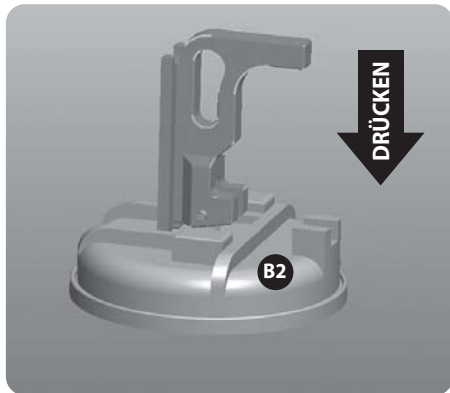

- 3) Lösen Sie leicht die M 6 Drehknöpfe. Schieben Sie dann den gefalteten Multi-Funktions-Ständer in den Saugfuß bis zum Ende (siehe Pfeil unten)

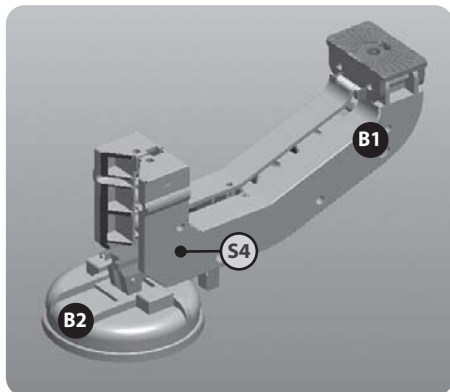
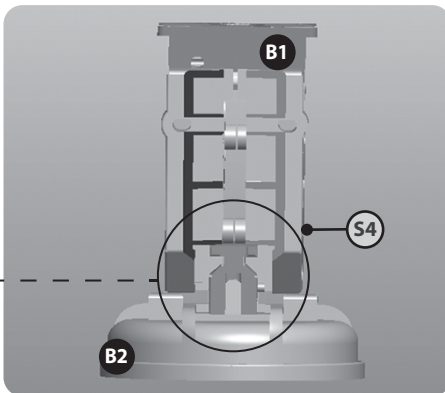
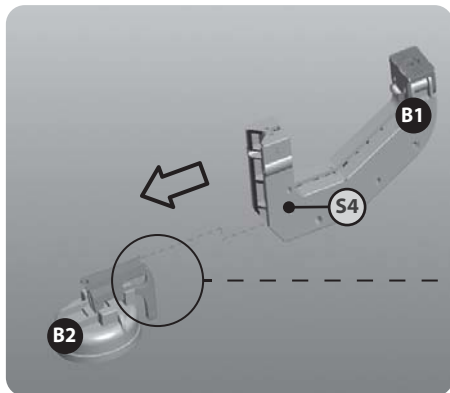

4) Befestigen Sie die Antenne mit den M 6 x 25 mm Schrauben

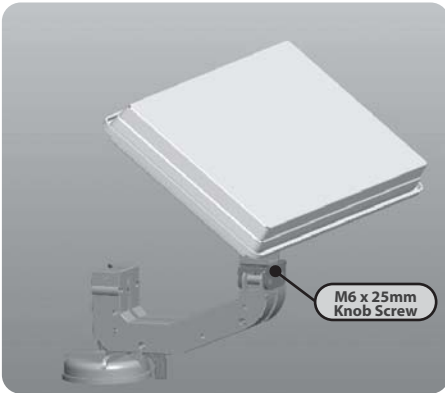

Methode 5

- 1) baisser la poignée de la ventouse en la serrant sur la surface plane
- 2) appuyer sur la poignée de la ventouse afin de bien la fixer

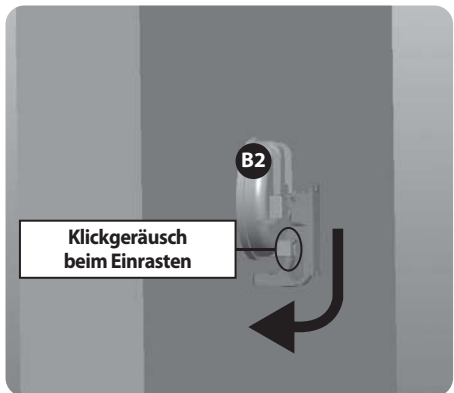
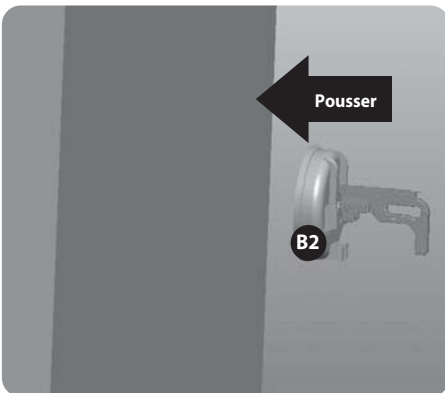

- 3) Lösen Sie leicht die M 6 Drehknöpfe
- 4) 4. Schieben Sie dann den gefalteten Multi-Funktions-Ständer in den Saugfuß bis zum Ende (siehe Pfeil unten)

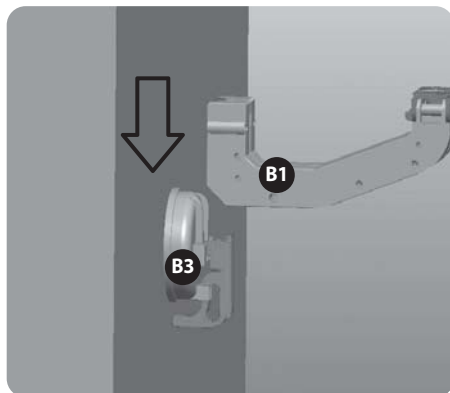

- 5) Ziehen Sie die M 6 Drehknöpfe fest, um den Multi-Funktions-Ständer zu befestigen
- 6) Befestigen Sie die Antenne mit den M 6 x 25 mm Schrauben

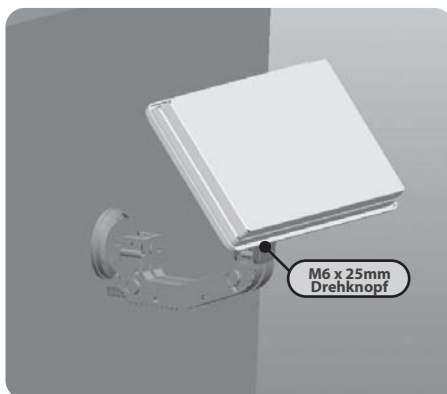
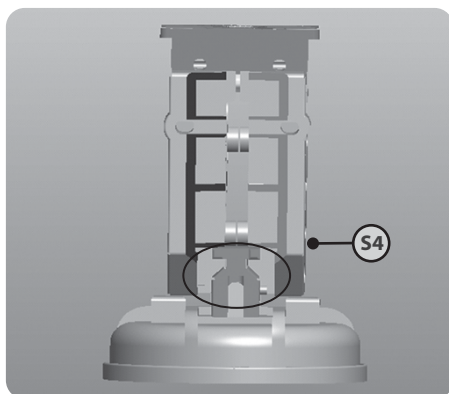

C) Einstellung von Elevation (Höhen-Neigung), Azimuth (Richtungs-Winkel) und Skew (Schiefstellung der Antenne)

Einstellung der Elevation

teilen Sie den Höhenwinkel (Elevation) grob entsprechend der Tabelle ein und befestigen Sie die Einstellung mit der M 6 x 25 mm Feststellschraube. (In unserem Beispiel ca. 30°)

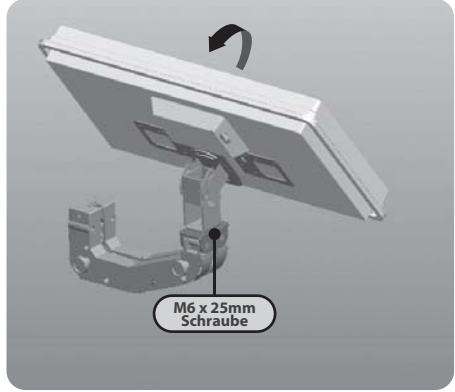
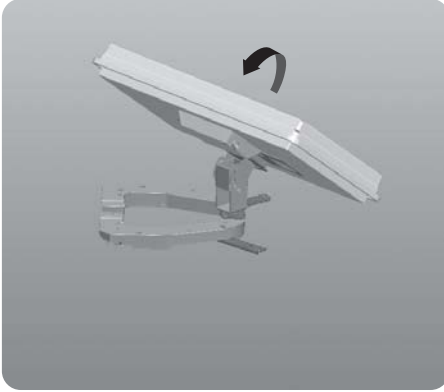

Einstellung von Azimuth

Entnehmen sie den passenden Winkel für die Richtung (Azimuth) der Tabelle und stellen die Antenne mit Hilfe des Kompass in die grobe Richtung ein. Befestigen Sie die Einstellung mit der M 6 x 25 mm Feststell- schraube. (In unserem Beispiel ca. 172°)

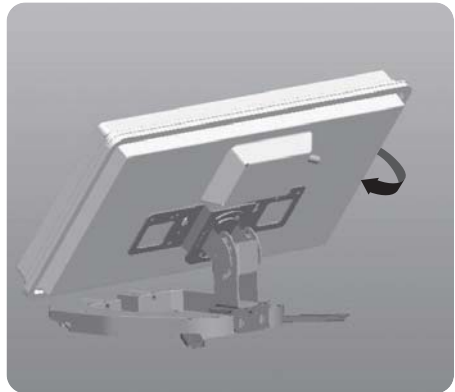

Einstellung des Skew

Entsprechend der Tabelle stellen Sie bitte den angegebenen Skew Winkel (Schiefstellung der Antenne) ein.

Befestigen Sie die Einstellung mit den Feststellschrauben auf der Rückseite der Antenne.

(In unserem Beispiel ca. 4°)

Hinweis: Diese Einstellung ist vor allem im Ausland sehr wichtig um eine optimale Empfangsleistung zu gewährleisten.

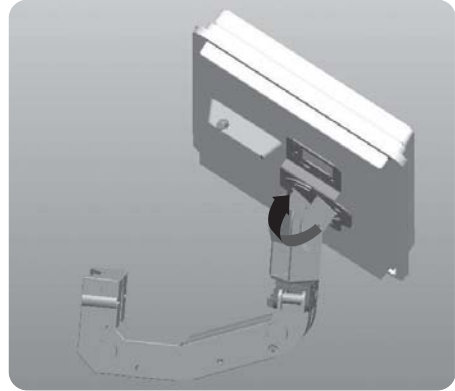
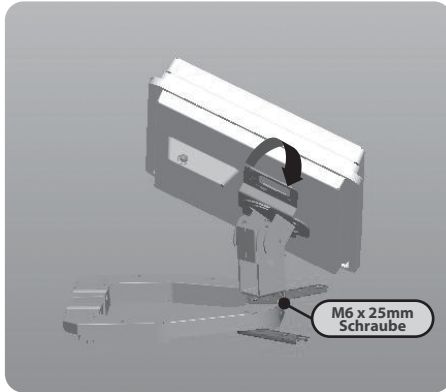

Schritt 4: Anschließen der Antenne an den Receiver

Sobald Sie die Antenne mit freier Sicht zum Himmel installiert wurde, ist der nächste Schritt alles miteinander zu verbinden.

Damit der Receiver ein Signal empfängt, muss er und die Antenne mit einem Kabel verbunden werden. Das Kabel zwischen der Antenne und dem Satellitenempfänger sollte nicht länger als 30 Meter sein, sonst verringert sich die Qualität des Signals. Die Verwendung eines langen Kabels oder eines schlecht isolierten Anschlusses kann den Verlust des Signalpegels bewirken.

A) Vorbereitung des Kabels

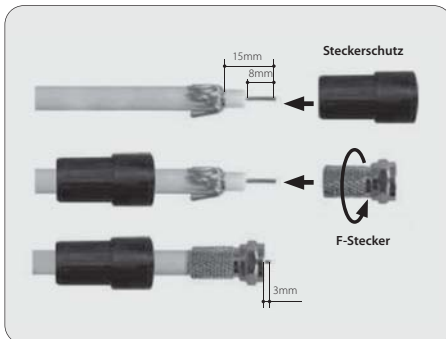

B) Kabel an der Antenne und den Receiver anschließen

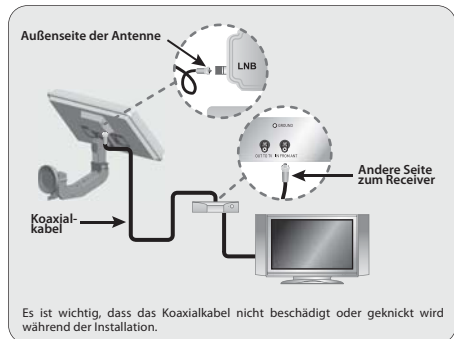

Schritt 5 : Feinabstimmung und Befestigung der Halterung

Wenn alles verbunden ist, schalten Sie den Receiver und den Fernseher ein. Wählen Sie das Antenneneinstellungsmenü in Ihrem Receiver aus.

Sie können den Signalpegel auf Ihrem TV überprüfen. Alternativ können Sie auch einen Satfinder benutzen. Weitere Informationen dazu entnehmen Sie bitte der Beschreibung Ihres Fernsehers oder Receivers. Überprüfen Sie die Einstellungen Ihres Receivers. In unserem Beispiel Astra1. Die Standardeinstellungen an Ihrem Receiver für diesen Satelliten sollten voreingestellt sein.

(LNB: Universal; LNB Spannung: EIN; Diseqc: Aus; 22Khz: Auto)

Wenn Sie keinen Blickkontakt zum Fernseher haben oder keinen Satfinder verwenden, ist eine weitere Person hilfreich, um den TV zu beobachten, und Ihnen sagt, wenn das Signal „gut“ ist, während Sie außerhalb sind um die Antenne zu justieren. Der Pegel und die Qualität auf dem TV-Bildschirm schwankt und ändern ggf. ihre Farbe nach je nachdem wie Sie die Antenne bewegen. Der Signalpegel zeigt die Leistung des Signals, die Signalqualität schlägt aus, wenn Sie sich auf dem richtigen, vorher ausgewählten Satelliten befinden. Bewegen Sie die Antenne nur langsam und in kleinen Schritten nach links/rechts - oben/unten, bis Sie den besten Wert erreicht haben. Beachten Sie bitte, dass der Receiver 2-3 Sekunden benötigt, bis er das Signal verarbeitet hat.

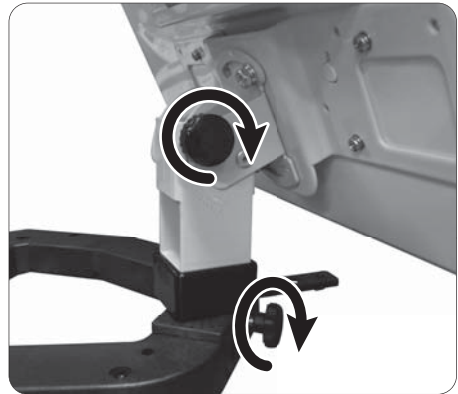
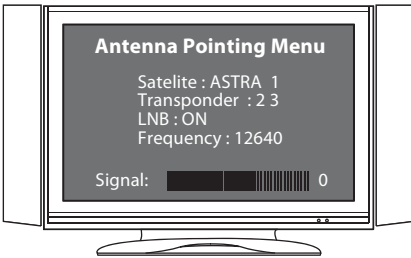

Checkliste zur Fehlerbehebung für die Erstinstallation

Wenn das Signal nicht gefunden wird, muss die Bedienungsanleitung des Receiver und der Antenne aufmerksam gelesen werden und ggf. nochmals die Einstellungen überprüft werden:

- Stellen Sie sicher, dass alle Kabelverbindungen korrekt angeschlossen sind und jede Verbindung ordnungsgemäß sitzt / festgeschraubt ist.
- Untersuchen Sie das Innere jedes Kabelsteckers auf Schmutz oder einen möglichen Kurzschluss.
- Überprüfen Sie die Azimuth, Elevation und Neigungswinkel passend zu Ihrem Ort über die Postleitzahl.
- Stellen Sie sicher, dass die Neigung und Höhe korrekt auf ihrer Skala ausgerichtet sind. Verwenden Sie keine Unterlegscheibe oder Schraube als Bezugspunkt.
- Stellen Sie sicher, dass der Neigungswinkel nicht von der empfohlenen Einstellung für den Ort der Antenne abweicht.
- Entfernen Sie vorhandene TV-spezifische Komponenten wie Multischalter, Sat-Verteiler, etc.: Reduzieren Sie die Installation auf die grundlegenden Verbindungen die in diesem Handbuch genannt werden. Zur Not schließen Sie das Koaxialkabel direkt an den Receiver an, um das Signal zu überprüfen.
- Stellen Sie sicher, dass keine Hindernisse im Weg sind (Bäume, Gebäude, Fenster, Ecken oder Überhänge Ihres Daches, Körper oder die Hände) - das Signal geht nicht durch Blätter, Äste, Glas etc.
- RG 6-Kabel mit festem Kupferkern-Leiter wird dringend empfohlen, weil es einen viel niedrigeren DC Spannungsabfall im Vergleich zur RG 6-Kabel mit einer Kupfer-beschichtete Stahlkern-Leiter hat.
- Standard RG 59-Kabel verursacht einen zu hohen Gleichstrom- und Signal-Abfall; es kann nicht verwendet werden, um das Satellitensignal weiterzuleiten. Ein RG 6-Koaxial-Kabel sollte verwendet werden.
- Stellen Sie sicher, dass das Satelliten-Kabel angeschlossen ist. Am Receiver muss das Kabel an der „LNB In“ Buchse und nicht an der „LNB Out“ Buchse angeschlossen werden.
- Wenn alles korrekt durchgeführt wurde und das Signal immer noch nicht gefunden wurde, ändern Sie die Höhenverstellung der Antenne etwas ($\pm 2^\circ$, dann $\pm 4^\circ$ von der ursprünglichen Einstellung) und wiederholen Sie den Vorgang. Made by Megasat

Signalverlust / Beeinträchtigung durch Regen

- Das Satellitensignal kann vorübergehend aufgrund eines ungewöhnlich starken Regens verloren gehen. Eine optimal ausgerichtete Antenne, zusammen mit dem kürzestmöglichen Kabelweg minimiert die Chancen bei Regen das Signal zu verlieren.
- Achten Sie darauf, dass die Antenne fest montiert ist, damit sie sich bei starkem Wind nicht verstellt.
- Starker Schneefall oder Schneeablagerungen auf der Antenne können ebenfalls das Signal beeinträchtigen. Fegen Sie den liegengelassenen Schnee von der Antenne.
- Wachsende Bäume oder Blätter unmittelbar vor der Antenne verringern von Zeit zu Zeit das Signal.

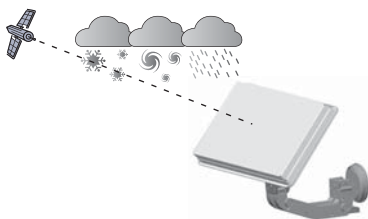

Contenu

Qu'est ce que SELFSAT - Traveler kit?

Qu'est ce que SELFSAT - Traveler kit?	2
---	---

Instructions de sécurité

Instructions de sécurité	2
--------------------------------	---

Contenu de la boîte

Contenu de la boîte	3
---------------------------	---

Comment Installer?

Comment Installer?	4
--------------------------	---

étape 1: Où installer?	4
------------------------------	---

étape 2: Informations à voir	5
------------------------------------	---

étape 3: Instructions de montage	5
--	---

A) Assemblage de la station de base multi-fonctions	5
---	---

B) Installer et fixer la station de base pour camping	7
---	---

C) ajuster l'azimuth et l'élévation	12
---	----

étape 4: Brancher l'antenne et le décodeur	13
--	----

A) Comment préparer le câble?	13
-------------------------------------	----

B) Comment brancher le câble à l'antenne et au décodeur?	13
--	----

étape 5: réglage fin et serrage des boulons de fixations	14
--	----

Dépannage et check-list pour installation primaire

Dépannage et check-list pour installation primaire	15
--	----

Signal perdu / pluie

Signal perdu / pluie	15
----------------------------	----

Qu'est ce que SELFSAT - Traveler kit?

SELSAT Traveler Kit est le plus concentré sur la portabilité, qui est né après la combinaison de l'antenne SELFSAT, ce qui a déjà été prouvé par un rendement élevé en utilisant la technologie de guidage d'ondes, et le tout nouveau système de bras de fixation portable qui est efficace et à utilisations diverses.

L'antenne SELFSAT utilise la technologie de guidage d'onde pour recevoir les satellites européens majeurs afin de remplacer les paraboles habituels, s'installe facilement avec une haute qualité de réception par rapport à sa taille.

Ainsi, le tout nouveau système de bras de fixation au design innovant permet divers types d'installations, comme sur une table (plan horizontal), fenêtre, rambarde etc... avec une flexibilité et maniabilité diverses.

La Combinaison de l'antenne SELFSAT et des bras de fixation sera un nouveau paradigme.













Instructions de sécurité

- Avant utilisation de ce produit veuillez lire attentivement ce manuel et suivre exactement toutes les instructions d'installation, de montage et d'orientation.
- Afin d'éviter les problèmes techniques, merci de suivre toutes les instructions.
- Tout champ électrique ou magnétique à côté de l'antenne peut affecter la réception et la qualité du signal reçu par celle-ci.
- Ne pas ouvrir le couvercle de l'antenne, qui la protège de l'humidité et des moisissures.
- Manipulez l'antenne avec précaution car tout choc risque d'endommager les composants électroniques.
- Ne pas ouvrir le couvercle, toute tentative de réparation par une personne non qualifiée peut être dangereuse et annulera la garantie.
- Tout obstacle (bâtiments, arbres, etc ...) bloquera la réception du signal provenant du satellite vers l'antenne.
- Ne peignez pas et n'ajoutez aucune substance sur le cache de l'antenne, cela bloquera la réception du signal du satellite.
- Le câble entre l'antenne et le récepteur satellite ne doit pas excéder 30m car cela diminuerait la qualité du signal.
- L'utilisation de connecteurs non isolés entraînera une perte de niveau de signal.
- Serrer toutes les vis de l'antenne lorsque vous avez terminé les réglages.
- Ce produit contient un LNB universel, il est interdit d'ajouter, de changer ou de modifier la LNB.
- Pour plus de précisions sur les points ci-dessus ou pour toute information, merci de s'adresser à votre revendeur ou le service client.

Avertissement

Antennes mal installées ou installées sur une structure inadéquate sont très sensibles aux dommages dus au vent. Ces dommages peuvent être très graves, voire mortelles. Le propriétaire et l'installateur assume l'entière responsabilité que l'installation est sensée supporter toutes les charges (poids, vent et glace) et l'étanchéité aux fuites. Le fabricant décline toute responsabilité pour tout dommage causé par une mauvaise installation du système.

Contenu

Non	Symbole	Nom des pièces	Image	Quantité
1	A1	Corps de l'antenne (Antenne, Bras de fixation d'angle)		1
2	B1	Station de base Multifonctions		1
3	B2	Ventouse		1
4	B4	Station de base fixation		1
5	B5	Manuel (En option)		1
6	B6	mallette de transport		1
7	C1	Boussole		1
8	S1	Vis type L		1
9	S2	Vis type U		1
10	S3	M6x65 Hex		2
11	S4	M6 écrou bouton		4
12	S5	M8 écrou bouton		1

Comment installer?

En suivant les instructions étape par étape, vous pouvez installer facilement SELFSAT-Traveler Kit par vous-même ou avec l'aide d'un installateur d'antenne professionnel.

Avant d'installer votre antenne, vérifiez que votre Kit SELFSAT-Traveler contient tous les éléments énumérés ci-dessus dans le «Contenu de la boîte». Dans le cas de pièces manquantes, merci de contacter votre distributeur.

étape 1: Où installer?

«Afin de recevoir le signal provenant du Satellite, SELFSAT-Traveler Kit doit être installé dans un espace à ciel ouvert (en dehors de la maison ou de l'appartement), dans la direction du satellite vers l'équateur, pour laquelle, vous avez besoin d'une boussole pour orienter avec exactitude SELFSAT-Traveler Kit vers le satellite.

Note

Merci de prendre compte du tableau des degrés d'angles d'Azimuth contenu dans les dernières pages de ce manuel d'utilisation.



< Boussole >

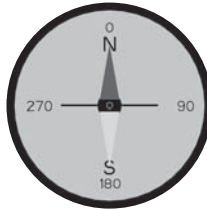

< Angle d'Azimuth >

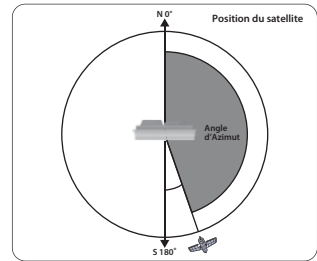

Note

Pour être sûre du bon fonctionnement de la boussole, restez à l'écart des objets métalliques, spécialement les câbles électriques et puis faire plusieurs essais.

Veillez vérifier qu'il y ait aucun obstacle devant l'antenne du SELFSAT-Traveler kit, ce qui peut entraîner une diminution de la qualité du signal, comme des immeubles ou des arbres (noter à ce que les arbres peuvent grandir et bloquer le signal plus tard).

Afin de pouvoir fixer et installer votre antenne facilement, vous devez choisir un emplacement facile d'accès sans aucun danger potentiel pour l'installation.

Pensez à la façon de passer votre câble le plus discrètement possible depuis l'antenne SELFSAT Traveler kit vers le décodeur. L'antenne ne doit pas être très distante du décodeur, une longueur de câble plus que 30 mètres peut engendrer des pertes de la qualité du signal.

Mauvaise qualité de la réception du signal

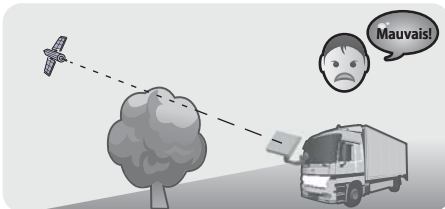

Bonne qualité de la réception du signal

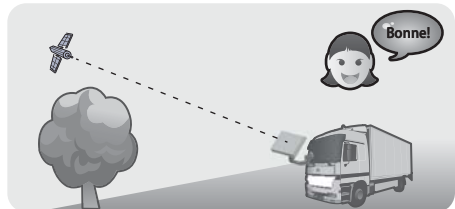

étape 2: Informations à voir

Pour installer l'antenne, vous devez trouver l'inclinaison, l'élévation et l'angle d'azimut en se référant au tableau vers la fin du manuel. Si vous ne trouvez pas votre location, merci de se référer à l'information de l'endroit le plus proche de votre position. Ce manuel vous montrera l'exemple d'installation pour recevoir ASTRA1 par satellite dans la région de Brest en France. L'information d'angle pour la région de Brest est Skew: -19,7, El: 30, Az: 149,6

étape 3: Instructions de montage

A) Assemblage de la station de base multi-fonctions

- 1) Ouverture de la station de base multi-fonctions
 - Ouvrir les deux ailes de la station de base multi-fonctions

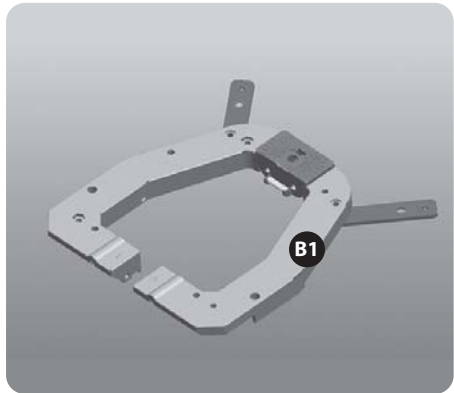
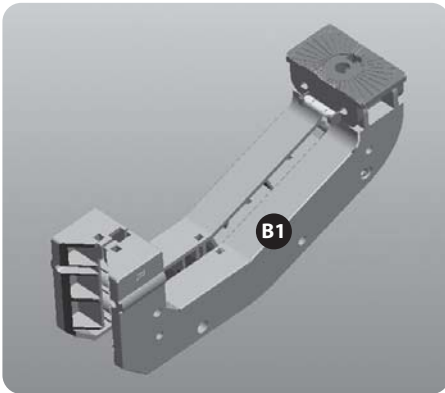

- Sortez le support de base, puis le mettre à plat

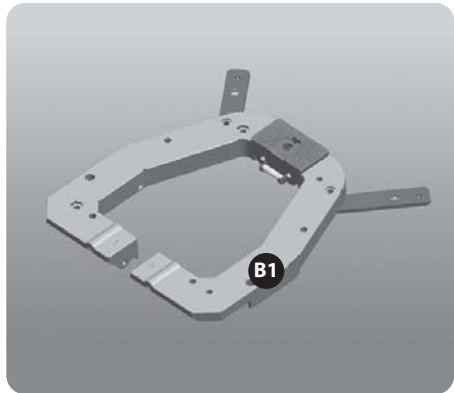
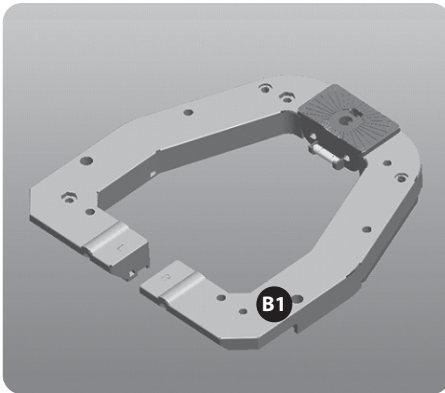

2) Replier la Base multi-fonctionnelle

- Utilisez les deux vis à tête hexadécimale à M6x65mm. Et les deux écrous M6 Bouton pour fixer la Base multi-fonctionnelle

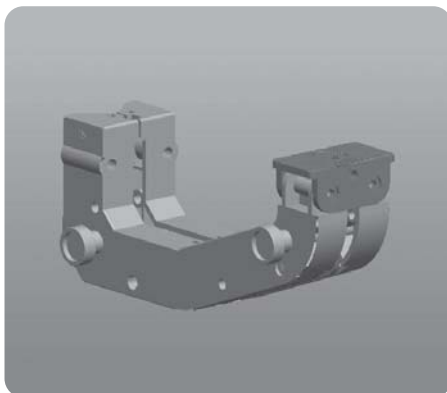
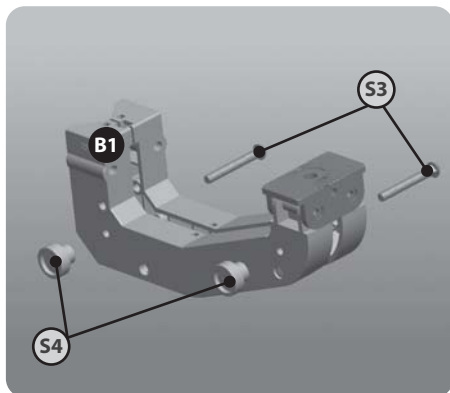

B) Installer et fixer la base du set de camping

Type 1

- 1) Mettre la station de base multi-fonctions ouverte sur la table
- 2) Placez le côté long du boulon Type-L dans la plaque Fixe et le côté court dans la Base multi-fonctionnelle

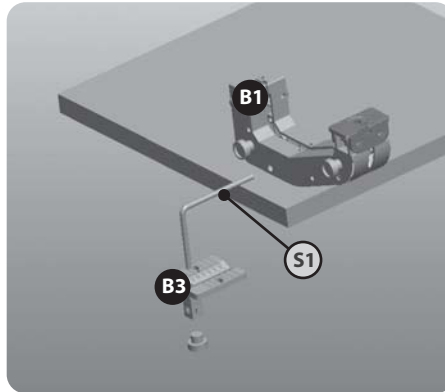

- 3) Utilisez le Bouton Écrou M8 pour fixer la plaque Fixe et la base multi-fonctionnelle
- 4) Insérez l'antenne sur la station de base multi-fonctions à l'aide des vis M6x25mm pour fixer le set de camping sur une table

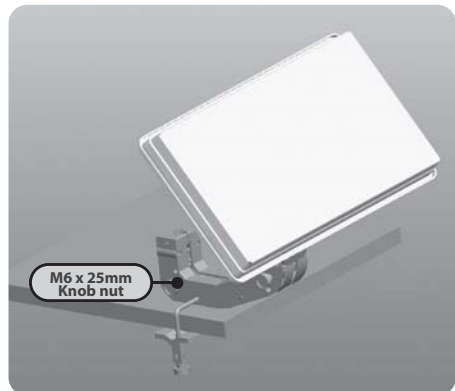
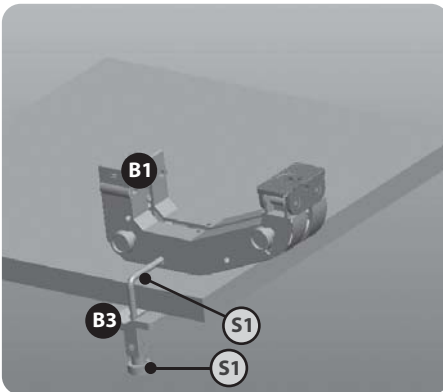

Type 2

- 1) Mettre la station de base multi-fonctions sur le mât en insérant les vis type U ver l'arrière. Ensuite visser par l'arrière du mât avec les écrous M6 afin de bien la fixer
- 2) Insérer l'antenne sur la station de base multi-fonctions en utilisant les vis M6x25mm, visser le set de camping comme suit

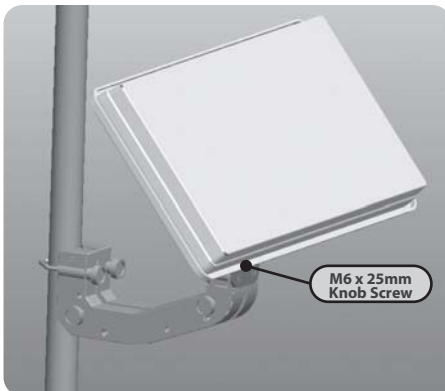
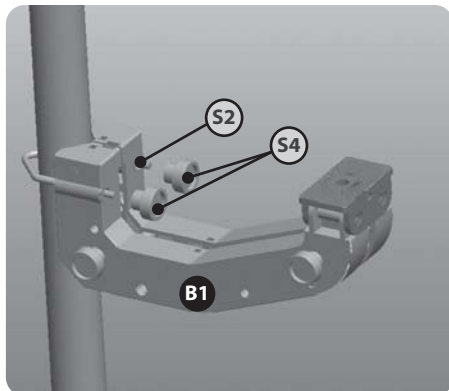

Type 3

- 1) Prendre la station de base multi-fonctions en l'ouvrant et insérer les vis M6x25mm
- 2) Insérer l'antenne sur la station de base multi-fonctions déjà ouverte. Puis serrer les vis M6x25mm

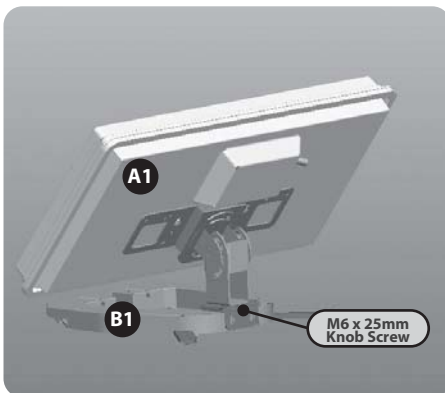
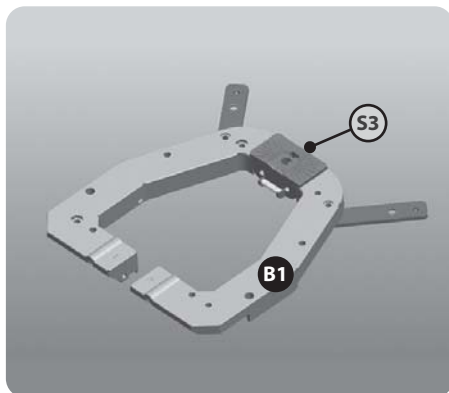

Type 4

- 1) Prendre la ventouse et soulever la poignée de celle-ci, la pousser sur une surface plane
- 2) Appuyer sur la poignée et la baisser afin de tirer la ventouse et chasser l'air pour bien la fixer

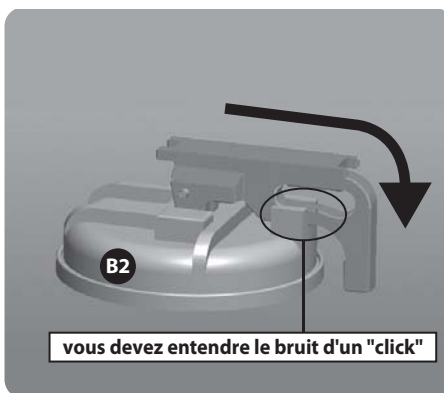
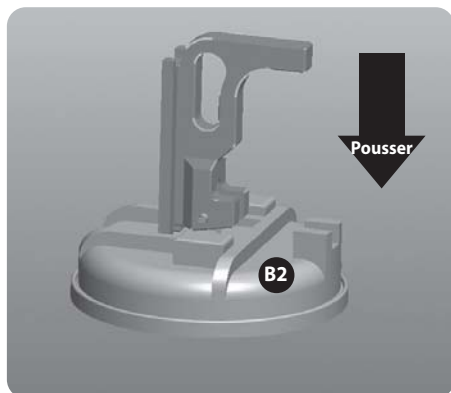

- 3) Insérer les vis M6, puis rentrer la station de base multi-fonctions sur la poignée de la ventouse (selon la flèche rouge)

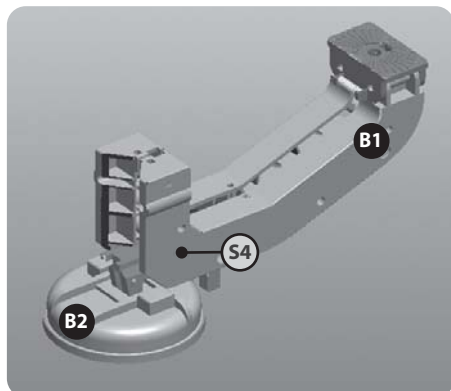
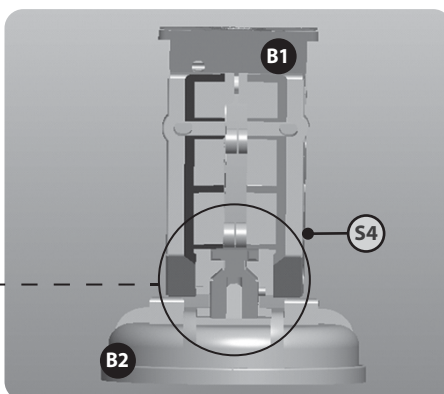
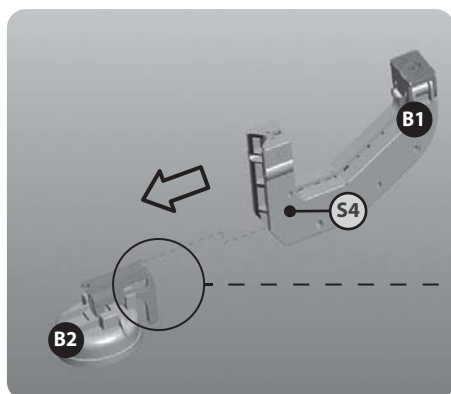

- 4) Insérer l'antenne sur la station de base multi-fonctions et visser les vis M6x25mm pour bien fixer l'ensemble

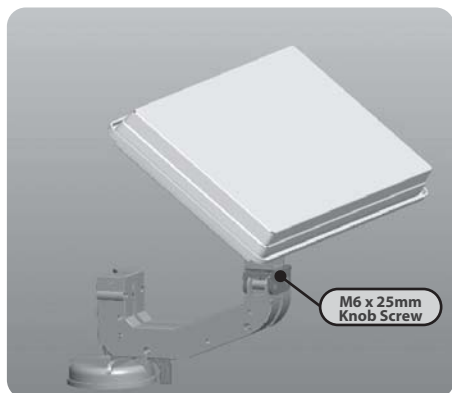

Type 5

- 1) baisser la poignée de la ventouse en la serrant sur la surface plane
- 2) appuyer sur la poignée de la ventouse afin de bien la fixer

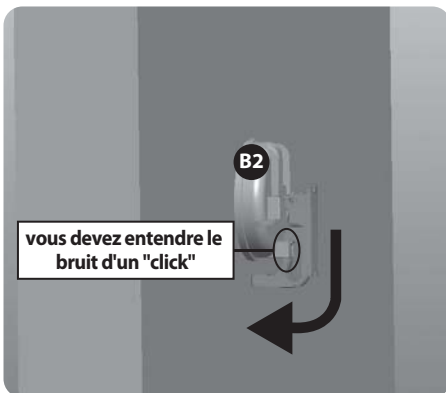
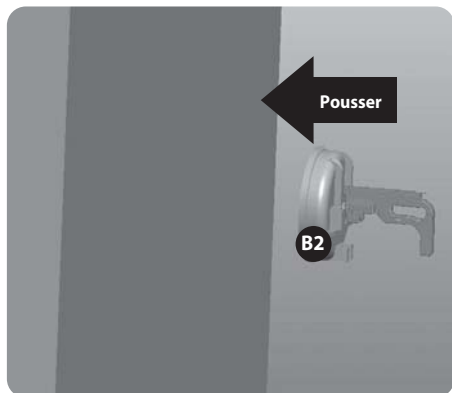

- 3) visser les vis M6
- 4) insérer la station de base multi-fonctions sur la ventouse

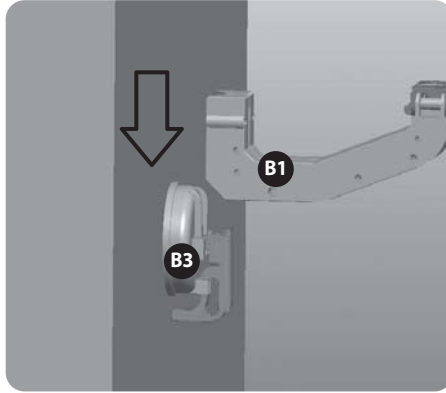

- 5) serrer les vis M6 par les écrous de la station de base-multifonction afin de la fixer sur la ventouse
- 6) Insérer l'antenne sur la station de base multi-fonctions et visser les vis M6x25mm pour bien fixer l'ensemble

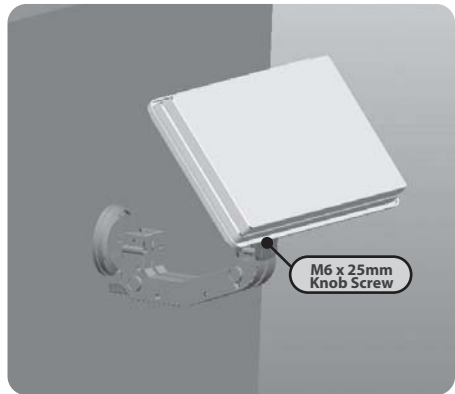
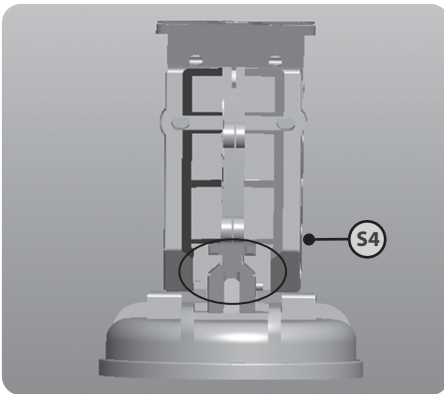

C) Réglage de l'angle (Contre polar, élévation, l'azimut)

Réglage de le contre polarité

- Reportez-vous à la table d'angle, réglez l'angle exact, puis serrez avec le boulon M6x18mm.
- L' Angle de contre polarité est un facteur important pour un signal optimisé.

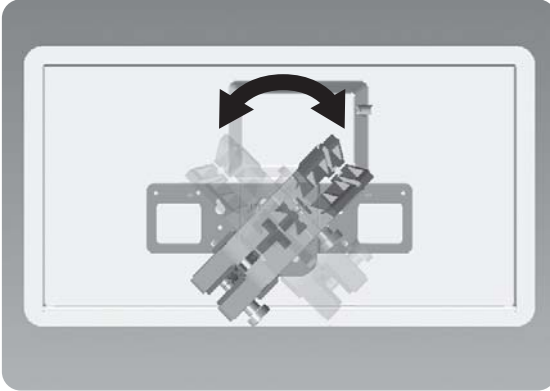

Réglage de l'élévation

- Reportez-vous à la table d'angle, réglez l'angle d'élévation locale.

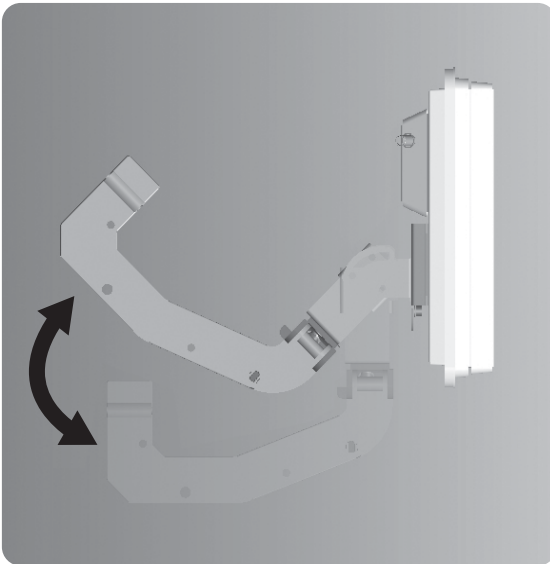

Réglage de l'azimut

- Vérifiez si vous avez toujours l'image tout en ajustant l'antenne.

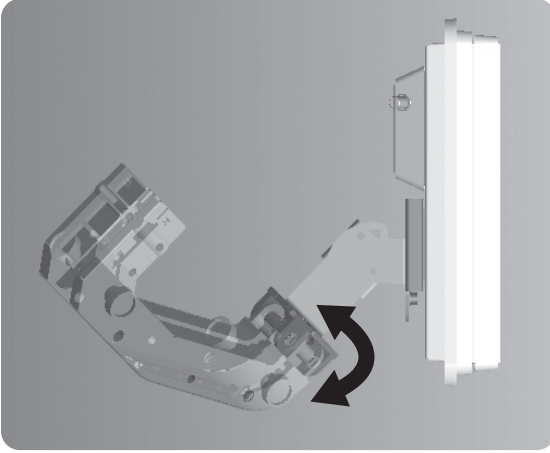

- Trouver l'angle d'élévation optimisé et l'angle d'azimut, puis serrer avec le boulon.

étape 4: Brancher l'antenne et le décodeur

Une fois l'antenne installée selon la façon et le type voulu, sans obstacles devant, la prochaine étape serait de brancher l'ensemble au décodeur.

Pour être capable de recevoir vos chaînes favorites du satellite voulu, vous devez brancher l'ensemble à votre décodeur par un câble coaxial. La longueur du câble ne doit pas dépasser les 30 mètres, sinon la qualité du signal diminue. L'utilisation d'un long câble ou de mauvaise qualité ainsi que des fiches F non isolées peut causer la rupture du signal, il est préférable d'utiliser un câble coaxial RG6 (HF 17VATC ou 19VATC), afin de minimiser la perte.

A) Comment préparer le câble?

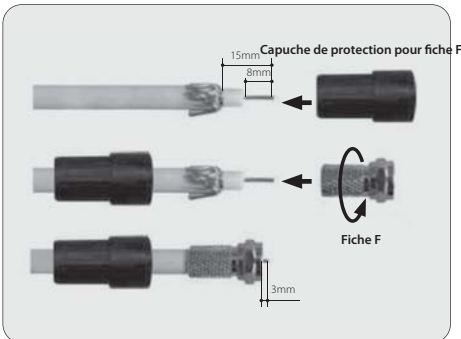

B) Comment connecter le câble à l'antenne et au décodeur?

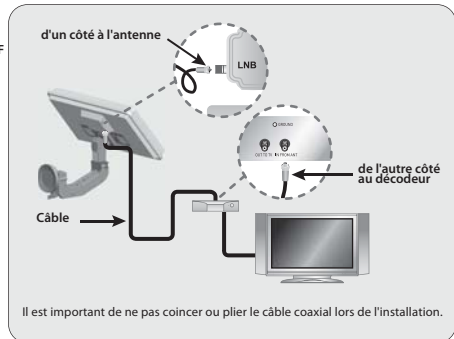

Etape 5 : Réglage fin et serrage des vis

Une fois le réglage fin complété, merci de bien serrer toute la visserie de l'ensemble de l'installation.

"Une fois que tout est connecté, allumez le téléviseur et le récepteur satellite. Sélectionnez le Menu de pointage de l'antenne sur votre décodeur. Vous pouvez vérifier le niveau du signal sur votre écran. N'oubliez pas de choisir : alimentation LNB "OUI" Vous aurez besoin de quelqu'un devant l'écran afin de vous indiquer si le niveau du signal est "Très bien" lors de votre ajustement de l'antenne à l'extérieur.

Le niveau du signal et la qualité seront indiqués sur l'écran de votre téléviseur, la barre va évoluer et changer de couleur selon vos ajustements et les mouvements que vous allez effectuer en bougeant l'antenne afin de pointer et trouver le satellite voulu (azimuth et angle d'élévation). La barre de niveau indique la force du signal et la couleur la qualité de réception depuis le satellite choisi.

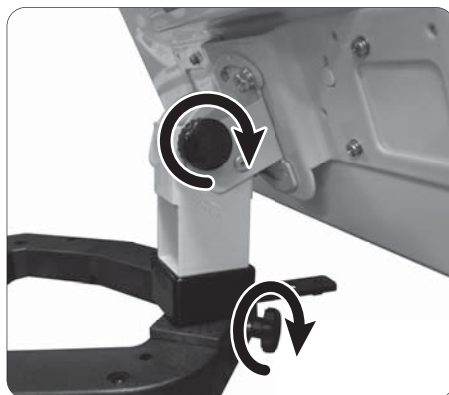
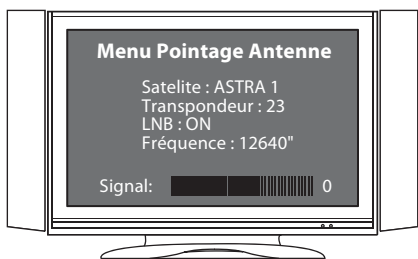

Dépannage et check-list pour installation primaire

Si vous n'avez pas de signal, merci de s'assurer que vous avez suivi à la lettre les instructions sur le manuel d'utilisation de votre décodeur et de l'antenne, voir suivant:

- S'assurer que tous les câbles sont bien connectés, isolés et bien serrés.
- Inspecter l'intérieur de chaque fiche F et s'assurer qu'il n'y ait aucune saleté ou bien un câble mal inséré.
- Vérifier que les angles d'azimut, d'élévation et d'inclinaison sont bien ceux de votre location par code Postal ZIP.
- S'assurer que le pointage d'inclinaison et d'élévation sont correctement choisis sur les graduations, ne pas prendre les vis comme référence.
- S'assurer que l'ajustement de l'angle d'inclinaison restent inchangés par rapport à votre location.
- Enlever tout composants spécifiques ajoutés à votre télé, comme des répartiteurs, etc, réduire l'installation à la forme basique établie dans ce manuel. Ce types de composants peuvent mal fonctionner avec le signal du satellite et peuvent être déjà encastrés dans les murs. Si moindre doute merci de branchez le câble en direct à votre décodeur sans passer par la prise murale.
- S'assurer qu'il n'y ait aucun obstacle devant l'antenne qui bloquerai le signal comme: (arbres, immeubles en face, le toit du balcon, vous-même) - le signal ne passe pas à travers les branches d'arbres, de vitres etc...
- Un câble RG 6 avec conducteur en cuivre massif central est fortement recommandé car il a une chute de tension beaucoup plus faible par rapport à un câble RG 6 avec un conducteur revêtu de cuivre, et un centre en acier.
- Le câble Standard RG 59 entraîne une chute DC et une chute de signal, il ne peut pas être utilisé pour transmettre le signal satellite. Un Câble coaxial RG 6 doit être utilisé.
- Certains composants ne sont comme annoncés. Ils pourraient ne pas fonctionner ou entraîner des chutes DC supplémentaires et d'atténuation d'amplitude du signal. Enlevez ces composants. Retour aux connexions de base stipulées dans ce manuel et re-vérifier.
- Assurez-vous que le câble du satellite est connecté à la «Sat In», pas le «Antenna In», le «Antenna In» à l'arrière du récepteur est pour l'entrée antenne hertzienne ou entrée télévision par câble.
- Si tout se fait correctement mais le signal n'est toujours pas trouvé. Modifier le réglage d'élévation de l'antenne légèrement ($\pm 2^\circ$, $\pm 4^\circ$ à partir de votre installation actuelle) et répétez la procédure.
- Assurez-vous que la carte d'accès à partir de votre récepteur est complètement insérée dans la fente de la carte d'accès et correctement orientée.

Perte de Signal / Pluie

- Le signal du satellite peut être temporairement perdu à cause des pluies exceptionnellement fortes. Une antenne pointée de manière optimale, avec le câble le plus court possible minimise les chances de perte en cas de «rideau de pluie».
- Assurez-vous que l'antenne soit fixée solidement pour l'empêcher d'être soufflé hors de l'alignement lors d'intempéries..
- L'accumulation de neige sur l'antenne peut réduire la puissance du signal satellite, la neige doit être balayée dès que possible.
- La croissance du feuillage dans la ligne de mire de l'antenne peut entraîner une perte progressive de l'image.

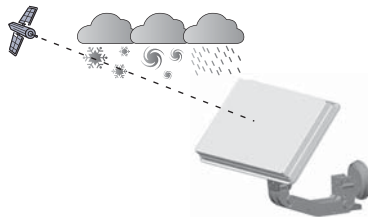



Flat Satellite Antenna

Note

As for an area not stated in the table, you can visit to www.selfsat.com and find it from the column of Satellite finder under Customer service.

Belgium

E=East Longitude W=West Longitude N= North Latitude S= South Latitude Az=Azimuth El=Elevation Sk=Skew

		Türksat	ASTRA 5	ASTRA 2	ASTRA 3	ASTRA 1	Eutelsat 16	Eutelsat Holbird 13	Eutelsat 9	SES 5 / ASTRA 4	Thor / Intelsat 10 02	Eutelsat 5W	Hispasat
		42.0° East	31.5° East	28.2° East	23.5° East	19.2° East	16.0° East	13.0° East	9.0° East	4.8° East	0.8° West	5.0° West	30.0° West
Antwerpen N 51.2, E 4.4	Az	135.3	146.7	150.5	156.0	161.3	165.2	169.0	174.1	179.5	186.9	192.0	221.3
	El	21.7	26.1	27.3	28.7	29.7	30.4	30.8	31.2	31.4	31.2	30.7	23.1
	Sk	-26.1	-13.1	-11.0	-7.7	-4.6	-9.2	-6.9	-3.7	-0.3	4.3	7.5	24.4
Arlon N 49.7, E 5.8	Az	136.2	147.8	151.6	157.3	162.7	166.7	170.6	175.8	181.3	188.9	194.0	223.4
	El	23.5	28.0	29.1	30.6	31.6	32.2	32.6	32.9	33.0	32.6	32.1	23.7
	Sk	-26.6	-13.2	-10.9	-7.5	-4.1	-8.5	-6.1	-2.7	0.9	5.7	9.0	26.4
Bastogne N 50.0, E 5.7	Az	136.2	147.8	151.6	157.3	162.6	166.7	170.5	175.7	181.2	188.7	193.9	223.2
	El	23.2	27.7	28.8	30.2	31.3	31.9	32.3	32.6	32.7	32.3	31.8	23.5
	Sk	-26.4	-13.1	-10.8	-7.4	-4.1	-8.5	-6.1	-2.8	0.8	5.6	8.9	26.1
Bergen N 50.5, E 4.0	Az	134.6	146.0	149.8	155.4	160.6	164.6	168.4	173.5	179.0	186.5	191.6	221.2
	El	22.0	26.6	27.8	29.3	30.4	31.0	31.5	32.0	32.1	32.0	31.5	23.9
	Sk	-26.9	-13.8	-11.7	-8.4	-5.2	-9.7	-7.4	-4.1	-0.7	4.1	7.4	24.8
Brügge N 51.2, E 3.2	Az	134.1	145.4	149.1	154.6	159.8	163.8	167.5	172.6	178.0	185.4	190.5	220.0
	El	21.1	25.7	26.9	28.3	29.5	30.2	30.7	31.1	31.4	31.3	30.9	23.7
	Sk	-26.7	-13.9	-11.8	-8.6	-5.5	-10.1	-7.8	-4.7	-1.3	3.4	6.5	23.8
Brüssel N 50.8, E 4.4	Az	135.2	146.6	150.4	155.9	161.2	165.2	169.0	174.1	179.5	187.0	192.1	221.5
	El	22.0	26.5	27.6	29.1	30.2	30.8	31.3	31.7	31.8	31.6	31.1	23.5
	Sk	-26.5	-13.4	-11.2	-7.9	-4.8	-9.3	-7.0	-3.7	-0.3	4.4	7.6	24.7
Charleroi N 50.4, E 4.5	Az	135.1	146.5	150.3	155.9	161.2	165.2	169.0	174.2	179.6	187.1	192.3	221.7
	El	22.3	26.9	28.0	29.5	30.6	31.2	31.7	32.1	32.3	32.0	31.6	23.7
	Sk	-26.7	-13.6	-11.4	-8.1	-4.9	-9.4	-7.0	-3.7	-0.3	4.5	7.8	25.1
Eupen N 50.6, E 6.0	Az	136.8	148.3	152.2	157.8	163.1	167.2	171.0	176.1	181.6	189.0	194.1	223.2
	El	22.9	27.2	28.3	29.7	30.7	31.3	31.7	32.0	32.0	31.7	31.1	22.9
	Sk	-25.8	-12.5	-10.2	-6.9	-3.6	-8.1	-5.7	-2.5	1.0	5.7	8.9	25.8
Gent N 51.0, E 3.7	Az	134.5	145.9	149.6	155.1	160.4	164.3	168.1	173.2	178.6	186.0	191.1	220.6
	El	21.5	26.0	27.2	28.7	29.8	30.5	30.9	31.4	31.6	31.4	31.0	23.6
	Sk	-26.7	-13.7	-11.6	-8.3	-5.2	-9.8	-7.5	-4.3	-0.9	3.8	7.0	24.2
Hasselt N 50.9, E 5.3	Az	136.2	147.6	151.4	157.0	162.3	166.3	170.1	175.2	180.6	188.1	193.2	222.4
	El	22.3	26.7	27.8	29.2	30.2	30.8	31.3	31.6	31.7	31.4	30.9	23.0
	Sk	-25.9	-12.7	-10.6	-7.2	-4.1	-8.6	-6.2	-3.0	0.4	5.1	8.3	25.2
Kortrijk N 50.8, E 3.3	Az	134.1	145.3	149.1	154.6	159.8	163.8	167.6	172.7	178.1	185.5	190.7	220.3
	El	21.5	26.0	27.3	28.8	29.9	30.6	31.1	31.6	31.8	31.7	31.3	23.9
	Sk	-27.0	-14.1	-12.0	-8.7	-5.6	-10.2	-7.8	-4.6	-1.2	3.5	6.7	24.1
Leuven N 50.9, E 4.7	Az	135.5	146.9	150.7	156.3	161.6	165.6	169.4	174.5	179.9	187.3	192.4	221.7
	El	22.1	26.5	27.6	29.1	30.1	30.7	31.2	31.6	31.7	31.5	31.0	23.2
	Sk	-26.2	-13.1	-11.0	-7.7	-4.5	-9.1	-6.7	-3.5	-0.1	4.6	7.8	24.8
Lüttich N 50.6, E 5.6	Az	136.4	147.9	151.7	157.3	162.6	166.6	170.5	175.6	181.0	188.5	193.6	222.8
	El	22.7	27.1	28.2	29.6	30.6	31.2	31.6	31.9	32.0	31.7	31.2	23.1
	Sk	-26.0	-12.7	-10.5	-7.2	-3.9	-8.4	-6.0	-2.8	0.7	5.4	8.6	25.6
Malmedy N 50.4, E 6.0	Az	136.7	148.2	152.1	157.8	163.1	167.1	171.0	176.1	181.6	189.1	194.2	223.3
	El	23.0	27.4	28.5	29.9	30.9	31.5	31.9	32.2	32.2	31.9	31.3	23.0
	Sk	-25.9	-12.6	-10.4	-7.0	-3.7	-8.2	-5.8	-2.5	1.0	5.8	9.0	25.9
Mecheln N 51.0, E 4.5	Az	135.4	146.8	150.5	156.1	161.4	165.3	169.1	174.2	179.6	187.1	192.2	221.5
	El	21.9	26.3	27.5	28.9	30.0	30.6	31.1	31.4	31.6	31.4	30.9	23.3
	Sk	-26.2	-13.2	-11.0	-7.8	-4.6	-9.2	-6.8	-3.6	-0.2	4.4	7.6	24.6
Namur N 50.5, E 4.9	Az	135.6	147.0	150.8	156.4	161.7	165.7	169.6	174.7	180.1	187.6	192.7	222.1
	El	22.5	26.9	28.1	29.5	30.6	31.2	31.6	32.0	32.1	31.9	31.4	23.5
	Sk	-26.4	-13.3	-11.1	-7.7	-4.5	-9.0	-6.6	-3.4	0.1	4.8	8.1	25.3
Eende N 51.2, E 2.9	Az	133.8	145.0	148.8	154.3	159.4	163.4	167.1	172.2	177.6	185.0	190.1	219.7
	El	21.0	25.5	26.7	28.3	29.4	30.1	30.6	31.1	31.4	31.3	30.9	23.8
	Sk	-26.9	-14.1	-12.0	-8.8	-5.7	-10.3	-8.0	-4.9	-1.5	3.1	6.3	23.6

Denmark

E=East Longitude W=West Longitude N= North Latitude S= South Latitude Az=Azimuth El=Elevation Sk=Skew

		ASTRA 5	ASTRA 2	ASTRA 3	ASTRA 1	Eutelsat 16	Eutelsat Hotbird 13	Eutelsat 10	Eutelsat 9	Eutelsat 7	SES 5/ ASTRA 4	Thor / Intelsat 10 02	Eutelsat 5W
		31.5° East	28.2° East	23.5° East	19.2° East	16.0° East	13.0° East	10.0° East	9.0° East	7.0° East	4.8° East	0.8° West	5.0° West
Alborg N 57.1, E 9.9	Az	154.8	158.5	163.9	169.0	172.8	176.3	179.9	181.1	183.5	186.1	192.9	197.6
	El	22.3	23.0	23.9	24.5	24.8	25.0	25.0	25.0	25.0	24.9	24.3	23.7
	Sk	-6.4	-4.5	-1.7	1.0	-3.9	-2.0	-0.1	0.6	1.9	3.3	7.0	9.4
Arhus N 56.2, E 10.2	Az	154.9	158.6	164.1	169.2	173.0	176.6	180.2	181.4	183.9	186.5	193.4	198.1
	El	23.2	24.0	24.9	25.5	25.8	25.9	26.0	26.0	25.9	25.8	25.2	24.6
	Sk	-6.7	-4.7	-1.8	1.0	-3.9	-1.9	0.1	0.8	2.1	3.6	7.4	10.0
Esbjerg N 55.5, E 8.5	Az	152.8	156.5	162.0	167.1	170.9	174.5	178.2	179.4	181.8	184.5	191.5	196.2
	El	23.5	24.3	25.3	26.0	26.4	26.6	26.7	26.7	26.7	26.7	26.2	25.6
	Sk	-8.0	-6.0	-3.1	-0.3	-5.1	-3.1	-1.0	-0.3	1.0	2.5	6.5	9.1
Helsingor N 56.1, E 12.6	Az	157.6	161.4	166.9	172.1	175.9	179.5	183.1	184.3	186.7	189.4	196.3	200.9
	El	23.9	24.6	25.4	25.8	26.0	26.1	26.1	26.0	25.9	25.7	24.9	24.2
	Sk	-5.3	-3.2	-0.2	2.6	-2.3	-0.3	1.8	2.4	3.8	5.2	9.0	11.5
Horsens N 57.1, E 10.1	Az	155.0	158.7	164.2	169.2	173.0	176.6	180.1	181.3	183.7	186.3	193.2	197.8
	El	22.3	23.1	24.0	24.5	24.8	25.0	25.0	25.0	25.0	24.9	24.3	23.7
	Sk	-6.3	-4.4	-1.5	1.2	-3.8	-1.9	0.1	0.7	2.0	3.4	7.1	9.6
Kobenhavn (Kopenhagen) N 55.7, E 12.6	Az	157.5	161.3	166.9	172.0	175.9	179.5	183.2	184.4	186.8	189.4	196.3	201.0
	El	24.3	25.0	25.8	26.2	26.5	26.5	26.5	26.4	26.3	26.1	25.4	24.6
	Sk	-5.5	-3.4	-0.4	2.5	-2.3	-0.3	1.8	2.5	3.8	5.3	9.1	11.7
Kolding N 55.5, E 9.5	Az	153.9	157.7	163.2	168.3	172.1	175.8	179.4	180.6	183.0	185.7	192.7	197.4
	El	23.7	24.5	25.5	26.1	26.5	26.7	26.7	26.7	26.7	26.6	26.0	25.4
	Sk	-7.4	-5.4	-2.4	0.4	-4.5	-2.4	-0.3	0.3	1.7	3.2	7.1	9.8
Odense N 55.4, E 10.4	Az	154.9	158.7	164.2	169.4	173.2	176.8	180.5	181.7	184.1	186.8	193.8	198.5
	El	24.1	24.8	25.8	26.4	26.6	26.8	26.8	26.8	26.8	26.6	26.0	25.3
	Sk	-7.0	-4.9	-1.9	1.0	-3.9	-1.8	0.3	1.0	2.3	3.9	7.8	10.4
Randers N 56.5, E 10.1	Az	154.8	158.6	164.1	169.1	172.9	176.5	180.1	181.3	183.7	186.4	193.2	197.9
	El	22.9	23.7	24.6	25.2	25.5	25.6	25.7	25.7	25.6	25.5	24.9	24.3
	Sk	-6.6	-4.6	-1.7	1.0	-3.9	-1.9	0.1	0.7	2.1	3.5	7.3	9.8
Roskilde N 55.7, E 12.1	Az	156.9	160.7	166.3	171.4	175.3	178.9	182.5	183.8	186.2	188.8	195.7	200.4
	El	24.2	24.9	25.7	26.2	26.4	26.5	26.5	26.5	26.4	26.2	25.4	24.7
	Sk	-5.8	-3.7	-0.7	2.2	-2.7	-0.6	1.4	2.1	3.5	5.0	8.8	11.3
Vejle N 55.7, E 9.6	Az	154.1	157.8	163.3	168.4	172.3	175.9	179.5	180.7	183.2	185.8	192.8	197.5
	El	23.6	24.4	25.3	25.9	26.3	26.5	26.5	26.5	26.5	26.4	25.8	25.2
	Sk	-7.3	-5.3	-2.3	0.5	-4.4	-2.3	-0.3	0.4	1.8	3.3	7.2	9.8

Finland

E=East Longitude W=West Longitude N= North Latitude S= South Latitude Az=Azimuth El=Elevation Sk=Skew

		ASTRA 5	ASTRA 2	ASTRA 3	ASTRA 1	Eutelsat 16	Eutelsat Hotbird 13	Eutelsat 10	Eutelsat 9	Eutelsat 7	SES 5/ ASTRA 4	Thor / Intelsat 1002	Eutelsat 5W
		31.5° East	28.2° East	23.5° East	19.2° East	16.0° East	13.0° East	10.0° East	9.0° East	7.0° East	4.8° East	0.8° West	5.0° West
Espoo N 60.2, E 24.7	Az	172.2	176.0	181.4	186.3	190.0	193.4	196.8	198.0	200.2	202.6	209.0	213.3
	El	21.5	21.7	21.7	21.6	21.3	21.0	20.6	20.4	20.1	19.7	18.4	17.3
	Sk	3.1	5.0	7.7	10.1	5.0	6.6	8.3	8.8	9.9	11.0	14.0	15.8
Helsinki N 60.1, E 25.0	Az	172.5	176.3	181.7	186.7	190.4	193.8	197.2	198.3	200.6	203.0	209.4	213.7
	El	21.6	21.8	21.8	21.7	21.4	21.1	20.7	20.5	20.1	19.7	18.4	17.3
	Sk	3.3	5.2	7.9	10.3	5.1	6.8	8.5	9.0	10.1	11.2	14.2	16.0
Jyväskylä N 62.3, E 25.8	Az	173.6	177.3	182.6	187.5	191.0	194.4	197.7	198.8	201.0	203.4	209.7	214.0
	El	19.4	19.5	19.5	19.3	19.0	18.7	18.3	18.2	17.8	17.4	16.2	15.1
	Sk	4.0	5.7	8.2	10.5	5.1	6.6	8.1	8.6	9.6	10.7	13.3	15.1
Kotka N 60.4, E 26.9	Az	174.7	178.5	183.9	188.8	192.5	195.9	199.3	200.4	202.6	205.0	211.3	215.6
	El	21.4	21.5	21.5	21.2	20.9	20.5	20.0	19.9	19.5	19.0	17.6	16.5
	Sk	4.4	6.3	8.9	11.4	6.1	7.8	9.4	9.9	10.9	12.1	14.9	16.7
Kuopio N 62.9, E 27.7	Az	175.7	179.4	184.7	189.5	193.1	196.4	199.7	200.8	203.0	205.4	211.6	215.8
	El	18.8	18.9	18.8	18.5	18.2	17.9	17.4	17.3	16.9	16.5	15.2	14.1
	Sk	5.1	6.7	9.2	11.3	5.9	7.4	8.8	9.3	10.3	11.3	13.8	15.5
Lahti N 61.0, E 25.7	Az	173.4	177.1	182.5	187.4	191.1	194.5	197.8	198.9	201.2	203.6	209.9	214.2
	El	20.7	20.8	20.9	20.7	20.4	20.1	19.6	19.5	19.1	18.7	17.4	16.3
	Sk	3.8	5.6	8.2	10.6	5.3	7.0	8.5	9.1	10.1	11.2	14.0	15.8
Oulu N 65.0, E 25.4	Az	173.3	176.9	182.1	186.8	190.4	193.6	196.9	198.0	200.2	202.5	208.7	212.9
	El	16.5	16.6	16.7	16.5	16.3	16.0	15.7	15.5	15.3	14.9	13.8	12.9
	Sk	4.2	5.7	7.9	9.9	4.4	5.7	7.1	7.5	8.4	9.3	11.7	13.3
Pori N 61.5, E 21.8	Az	169.0	172.7	178.1	183.0	186.6	190.0	193.4	194.5	196.7	199.2	205.6	209.9
	El	19.9	20.1	20.3	20.3	20.2	20.0	19.7	19.5	19.3	18.9	17.8	16.9
	Sk	1.8	3.5	6.1	8.4	3.1	4.8	6.3	6.9	7.9	9.0	11.9	13.8
Tampere N 61.5, E 23.8	Az	171.3	175.0	180.3	185.2	188.9	192.3	195.6	196.7	199.0	201.4	207.7	212.0
	El	20.1	20.3	20.4	20.2	20.0	19.8	19.4	19.3	19.0	18.6	17.4	16.4
	Sk	2.8	4.6	7.2	9.5	4.2	5.8	7.4	7.9	8.9	10.0	12.8	14.7
Turku N 60.5, E 22.3	Az	169.5	173.2	178.6	183.6	187.2	190.7	194.1	195.2	197.5	199.9	206.3	210.7
	El	21.0	21.2	21.4	21.4	21.2	21.0	20.6	20.5	20.2	19.8	18.7	17.7
	Sk	1.8	3.7	6.3	8.8	3.6	5.2	6.9	7.4	8.5	9.7	12.6	14.6
Vantaa N 60.3, E 25.0	Az	172.5	176.3	181.7	186.7	190.3	193.8	197.1	198.3	200.5	203.0	209.3	213.6
	El	21.4	21.6	21.6	21.4	21.2	20.9	20.4	20.3	19.9	19.5	18.2	17.1
	Sk	3.3	5.2	7.9	10.3	5.1	6.8	8.4	8.9	10.0	11.1	14.0	15.9

Luxembourg

E=East Longitude W=West Longitude N= North Latitude S= South Latitude Az=Azimuth El=Elevation Sk=Skew

		ASTRA 5	ASTRA 2	ASTRA 3	ASTRA 1	Eutelsat 16	Eutelsat Hotbird 13	Eutelsat 10	Eutelsat 9	Eutelsat 7	SES 5/ ASTRA 4	Thor / Intelsat 10 02	Eutelsat 5W
		31.5° East	28.2° East	23.5° East	19.2° East	16.0° East	13.0° East	10.0° East	9.0° East	7.0° East	4.8° East	0.8° West	5.0° West
Differdange N 49.5, E 5.9	Az	147.8	151.7	157.4	162.7	166.8	170.7	174.6	175.9	178.6	181.5	189.0	194.2
	El	28.2	29.4	30.8	31.8	32.4	32.8	33.1	33.2	33.2	33.2	32.9	32.3
	Sk	-13.3	-11.0	-7.5	-4.1	-8.5	-6.0	-3.5	-2.6	-0.9	0.9	5.9	9.2
Dudelange N 49.5, E 6.1	Az	148.0	151.9	157.6	163.0	167.1	171.0	174.9	176.2	178.8	181.7	189.3	194.5
	El	28.3	29.4	30.8	31.9	32.4	32.9	33.1	33.2	33.2	33.2	32.8	32.2
	Sk	-13.1	-10.8	-7.3	-4.0	-8.4	-5.9	-3.3	-2.5	-0.8	1.1	6.0	9.3
Esch N 49.5, E 6.0	Az	147.9	151.8	157.5	162.9	166.9	170.8	174.8	176.1	178.7	181.6	189.2	194.3
	El	28.2	29.4	30.8	31.8	32.4	32.8	33.1	33.2	33.2	33.2	32.8	32.3
	Sk	-13.2	-10.9	-7.4	-4.0	-8.4	-5.9	-3.4	-2.6	-0.9	1.0	5.9	9.3
Ettelbruck N 49.8, E 6.1	Az	148.1	152.0	157.7	163.1	167.1	171.0	174.9	176.2	178.8	181.7	189.3	194.4
	El	28.0	29.1	30.5	31.5	32.1	32.5	32.8	32.8	32.9	32.9	32.5	31.9
	Sk	-12.9	-10.6	-7.2	-3.8	-8.3	-5.8	-3.3	-2.5	-0.8	1.1	6.0	9.2
Luxembourg N 49.6, E 6.2	Az	148.2	152.1	157.8	163.1	167.2	171.1	175.0	176.3	179.0	181.8	189.4	194.6
	El	28.2	29.4	30.8	31.8	32.4	32.8	33.0	33.1	33.1	33.1	32.7	32.1
	Sk	-13.0	-10.7	-7.2	-3.8	-8.2	-5.8	-3.2	-2.4	-0.7	1.2	6.1	9.4
Petange N 49.6, E 5.9	Az	147.8	151.7	157.4	162.8	166.8	170.7	174.6	175.9	178.6	181.4	189.0	194.2
	El	28.1	29.3	30.7	31.7	32.3	32.7	33.0	33.0	33.1	33.1	32.7	32.2
	Sk	-13.2	-10.9	-7.4	-4.1	-8.5	-6.0	-3.5	-2.6	-0.9	0.9	5.8	9.1
Remich N 49.6, E 6.4	Az	148.4	152.3	158.0	163.4	167.5	171.4	175.3	176.6	179.2	182.1	189.7	194.8
	El	28.3	29.4	30.8	31.8	32.4	32.8	33.0	33.1	33.1	33.1	32.7	32.1
	Sk	-12.9	-10.5	-7.1	-3.7	-8.1	-5.6	-3.1	-2.2	-0.5	1.4	6.3	9.6

Netherlands

E=East Longitude W=West Longitude N= North Latitude S= South Latitude Az=Azimuth El=Elevation Sk=Skew

		ASTRA 5	ASTRA 2	ASTRA 3	ASTRA 1	Eutelsat 16	Eutelsat Hotbird 13	Eutelsat 10	Eutelsat 9	Eutelsat 7	SES 5/ ASTRA 4	Thor/ Intelsat 10 02	Eutelsat 5W
		31.5° East	28.2° East	23.5° East	19.2° East	16.0° East	13.0° East	10.0° East	9.0° East	7.0° East	4.8° East	0.8° West	5.0° West
Alkmar N 52.7, E 4.7	Az	147.6	151.3	156.8	162.0	165.9	169.6	173.4	174.6	177.1	179.9	187.2	192.1
	El	24.9	25.9	27.3	28.3	28.8	29.3	29.6	29.6	29.7	29.8	29.5	29.1
	Sk	-12.0	-9.9	-6.8	-3.8	-8.5	-6.3	-4.0	-3.3	-1.8	-0.1	4.3	7.3
Almelo N 52.3, E 6.7	Az	149.7	153.5	159.1	164.4	168.3	172.1	175.8	177.1	179.6	182.4	189.7	194.7
	El	25.9	26.9	28.2	29.1	29.6	29.9	30.1	30.2	30.2	30.2	29.8	29.2
	Sk	-11.0	-8.8	-5.6	-2.5	-7.1	-4.9	-2.6	-1.8	-0.2	1.5	5.9	8.9
Amsterdam N 52.4, E 4.9	Az	147.7	151.5	157.0	162.2	166.1	169.8	173.6	174.8	177.4	180.1	187.4	192.4
	El	25.2	26.3	27.6	28.6	29.2	29.6	29.9	30.0	30.1	30.1	29.8	29.4
	Sk	-12.0	-9.9	-6.8	-3.8	-8.4	-6.2	-3.9	-3.2	-1.6	0.1	4.5	7.5
Apeldoorn N 52.2, E 6.0	Az	148.9	152.7	158.3	163.5	167.4	171.2	174.9	176.2	178.7	181.5	188.8	193.8
	El	25.8	26.8	28.1	29.0	29.6	29.9	30.2	30.2	30.3	30.3	29.9	29.4
	Sk	-11.5	-9.3	-6.1	-3.0	-7.7	-5.4	-3.1	-2.3	-0.8	0.9	5.4	8.4
Arnhem N 52.0, E 5.9	Az	148.7	152.5	158.1	163.3	167.3	171.0	174.8	176.1	178.6	181.4	188.7	193.7
	El	25.9	27.0	28.3	29.2	29.8	30.1	30.4	30.4	30.5	30.5	30.2	29.6
	Sk	-11.7	-9.5	-6.3	-3.2	-7.8	-5.5	-3.2	-2.4	-0.9	0.9	5.4	8.4
Breda N 51.6, E 4.7	Az	147.2	151.0	156.5	161.7	165.7	169.5	173.3	174.5	177.1	179.9	187.3	192.3
	El	25.9	27.0	28.4	29.4	30.0	30.4	30.7	30.8	30.9	31.0	30.7	30.2
	Sk	-12.7	-10.5	-7.3	-4.2	-8.8	-6.5	-4.2	-3.4	-1.8	-0.1	4.5	7.6
Den Haag N 52.1, E 4.3	Az	146.9	150.7	156.2	161.4	165.3	169.0	172.8	174.1	176.6	179.4	186.7	191.7
	El	25.3	26.4	27.8	28.8	29.4	29.9	30.2	30.2	30.4	30.4	30.2	29.8
	Sk	-12.6	-10.5	-7.4	-4.3	-9.0	-6.7	-4.4	-3.7	-2.1	-0.4	4.1	7.2
Eindhoven N 51.4, E 5.5	Az	148.0	151.8	157.4	162.7	166.7	170.4	174.3	175.5	178.1	180.9	188.3	193.3
	El	26.3	27.4	28.8	29.8	30.3	30.7	31.0	31.1	31.2	31.2	30.8	30.3
	Sk	-12.3	-10.1	-6.9	-3.7	-8.3	-6.0	-3.6	-2.8	-1.2	0.6	5.2	8.3
Emmen N 52.8, E 6.9	Az	150.1	153.9	159.5	164.7	168.6	172.4	176.1	177.4	179.9	182.6	189.9	194.8
	El	25.5	26.5	27.7	28.6	29.1	29.4	29.6	29.6	29.7	29.6	29.2	28.6
	Sk	-10.5	-8.4	-5.2	-2.2	-6.9	-4.6	-2.4	-1.6	-0.1	1.6	6.0	8.9
Enschede N 52.2, E 6.9	Az	149.9	153.7	159.3	164.6	168.5	172.3	176.1	177.3	179.9	182.7	190.0	194.9
	El	26.1	27.1	28.3	29.2	29.7	30.0	30.2	30.3	30.3	30.3	29.8	29.3
	Sk	-10.9	-8.7	-5.5	-2.4	-7.0	-4.7	-2.4	-1.6	-0.1	1.6	6.1	9.1
Groningen N 53.0, E 6.6	Az	149.9	153.7	159.2	164.4	168.3	172.0	175.8	177.0	179.5	182.3	189.5	194.4
	El	25.0	26.0	27.2	28.1	28.6	28.9	29.1	29.2	29.2	29.2	28.8	28.3
	Sk	-10.5	-8.4	-5.3	-2.3	-7.0	-4.8	-2.5	-1.8	-0.3	1.4	5.7	8.6
Harlem N 52.4, E 4.6	Az	147.4	151.1	156.6	161.8	165.7	169.4	173.2	174.5	177.0	179.8	187.1	192.1
	El	25.1	26.2	27.6	28.6	29.1	29.6	29.9	29.9	30.0	30.1	29.9	29.4
	Sk	-12.2	-10.1	-7.0	-4.0	-8.7	-6.4	-4.2	-3.4	-1.9	-0.2	4.3	7.3
Hoogeveen N 52.7, E 6.5	Az	149.6	153.4	159.0	164.2	168.1	171.9	175.6	176.9	179.4	182.1	189.4	194.4
	El	25.5	26.5	27.7	28.6	29.1	29.5	29.7	29.7	29.8	29.7	29.4	28.8
	Sk	-10.9	-8.7	-5.6	-2.5	-7.2	-4.9	-2.7	-1.9	-0.4	1.3	5.7	8.6
Leeuwarden N 53.2, E 5.8	Az	149.0	152.8	158.3	163.4	167.3	171.0	174.8	176.0	178.5	181.3	188.5	193.4
	El	24.8	25.8	27.1	28.0	28.5	28.9	29.1	29.1	29.2	29.2	28.9	28.4
	Sk	-11.0	-8.9	-5.8	-2.8	-7.6	-5.4	-3.1	-2.4	-0.9	0.8	5.1	8.0
Maastricht N 50.8, E 5.7	Az	148.0	151.9	157.5	162.8	166.8	170.6	174.5	175.7	178.3	181.2	188.6	193.7
	El	26.9	28.1	29.4	30.4	31.0	31.4	31.7	31.7	31.8	31.8	31.5	30.9
	Sk	-12.5	-10.3	-7.0	-3.8	-8.3	-5.9	-3.5	-2.7	-1.1	0.7	5.4	8.6
Nijmegen N 51.8, E 5.9	Az	148.6	152.4	158.0	163.3	167.2	171.0	174.8	176.1	178.6	181.4	188.8	193.8
	El	26.1	27.2	28.5	29.4	30.0	30.4	30.6	30.7	30.7	30.7	30.4	29.9
	Sk	-11.8	-9.6	-6.4	-3.3	-7.9	-5.6	-3.2	-2.4	-0.9	0.9	5.4	8.5
Roermond N 51.2, E 6.0	Az	148.5	152.4	158.0	163.3	167.3	171.1	174.9	176.2	178.7	181.5	189.0	194.0
	El	26.7	27.8	29.1	30.1	30.6	31.0	31.3	31.3	31.4	31.4	31.0	30.5
	Sk	-12.1	-9.9	-6.6	-3.4	-8.0	-5.6	-3.2	-2.4	-0.8	1.0	5.6	8.7
Rotterdam N 51.9, E 4.5	Az	147.1	150.9	156.4	161.6	165.5	169.3	173.0	174.3	176.8	179.6	187.0	192.0
	El	25.5	26.6	28.0	29.0	29.7	30.1	30.4	30.5	30.6	30.6	30.4	30.0
	Sk	-12.6	-10.5	-7.3	-4.3	-8.9	-6.6	-4.3	-3.5	-2.0	-0.2	4.3	7.4
Tilburg N 51.6, E 5.1	Az	147.7	151.4	157.0	162.2	166.2	170.0	173.8	175.0	177.6	180.4	187.8	192.8
	El	26.0	27.1	28.5	29.5	30.1	30.5	30.8	30.8	30.9	30.9	30.7	30.2
	Sk	-12.4	-10.3	-7.1	-3.9	-8.5	-6.2	-3.9	-3.1	-1.5	0.2	4.8	7.9
Utrecht N 52.1, E 5.1	Az	147.8	151.6	157.1	162.3	166.3	170.0	173.8	175.1	177.6	180.4	187.7	192.7
	El	25.5	26.6	28.0	29.0	29.5	30.0	30.2	30.3	30.4	30.4	30.1	29.7
	Sk	-12.1	-10.0	-6.8	-3.7	-8.4	-6.1	-3.8	-3.0	-1.5	0.2	4.7	7.8
Venlo N 51.3, E 6.2	Az	148.8	152.6	158.2	163.5	167.5	171.3	175.1	176.4	179.0	181.8	189.2	194.2
	El	26.7	27.7	29.1	30.0	30.6	30.9	31.2	31.2	31.3	31.3	30.9	30.3
	Sk	-11.9	-9.7	-6.4	-3.2	-7.8	-5.4	-3.0	-2.2	-0.6	1.1	5.7	8.8
Warden N 53.1, E 5.8	Az	149.0	152.7	158.2	163.4	167.3	171.0	174.8	176.0	178.5	181.3	188.5	193.4
	El	24.9	25.9	27.2	28.1	28.6	29.0	29.2	29.3	29.3	29.3	29.0	28.5
	Sk	-11.0	-9.0	-5.9	-2.9	-7.6	-5.4	-3.2	-2.4	-0.9	0.8	5.1	8.0

Norway

E=East Longitude W=West Longitude N= North Latitude S= South Latitude Az=Azimuth El=Elevation Sk=Skew

		ASTRA 5	ASTRA 2	ASTRA 3	ASTRA 1	Eutels at 16	Eutelsat Holbird 13	Eutelsat 10	Eutelsat 9	Eutelsat 7	SES 5 / ASTRA 4	Thor / Intelsat 10 02	Eutelsat 5W
		31.5° East	28.2° East	23.5° East	19.2° East	16.0° East	13.0° East	10.0° East	9.0° East	7.0° East	4.8° East	0.8° West	5.0° West
Ålesund N 62.5, E 6.2	Az	152.0	155.5	160.7	165.4	169.0	172.3	175.7	176.8	179.1	181.6	187.9	192.6
	El	16.3	17.0	17.9	18.5	18.8	19.1	19.2	19.3	19.3	19.3	19.1	18.7
	Sk	-5.0	-3.5	-1.3	0.8	-5.1	-3.5	-2.0	-1.5	-0.4	8.2	3.6	5.8
Arendal N 58.5, E 8.8	Az	153.9	157.6	162.9	167.9	171.6	175.1	178.6	179.8	182.1	184.7	191.2	196.1
	El	20.7	21.4	22.3	22.9	23.2	23.4	23.5	23.5	23.5	23.4	23.0	22.5
	Sk	-5.8	-4.0	-1.3	1.2	-4.4	-2.6	-0.7	-0.1	1.1	10.0	5.8	8.3
Askøy N 60.5, E 5.2	Az	150.4	154.0	159.2	164.0	167.6	171.1	174.5	175.6	177.9	180.5	186.9	191.7
	El	17.9	18.7	19.7	20.4	20.8	21.1	21.3	21.3	21.4	21.4	21.2	20.9
	Sk	-6.6	-5.0	-2.6	-0.3	-6.1	-4.4	-2.7	-2.2	-1.0	7.7	3.4	5.7
Bærum N 59.9, E 10.5	Az	156.1	159.8	165.1	170.0	173.7	177.1	180.6	181.7	184.0	186.6	193.0	197.8
	El	19.7	20.4	21.1	21.6	21.9	22.0	22.0	22.0	22.0	21.9	21.4	20.8
	Sk	-4.2	-2.5	0.1	2.5	-3.2	-1.5	0.3	0.9	2.0	10.8	6.5	8.8
Bergen N 60.4, E 5.3	Az	150.5	154.1	159.3	164.1	167.7	171.2	174.6	175.8	178.1	180.6	187.0	191.8
	El	18.0	18.8	19.8	20.5	20.9	21.2	21.4	21.4	21.5	21.5	21.3	21.0
	Sk	-6.6	-5.0	-2.6	-0.3	-6.0	-4.4	-2.7	-2.1	-1.0	7.8	3.5	5.8
Drammen N 59.7, E 10.2	Az	155.7	159.4	164.7	169.6	173.3	176.8	180.2	181.4	183.7	186.3	192.7	197.5
	El	19.9	20.5	21.3	21.8	22.1	22.2	22.3	22.2	22.2	22.1	21.6	21.0
	Sk	-4.5	-2.7	-0.2	2.3	-3.4	-1.6	0.1	0.7	1.9	10.7	6.4	8.7
Førde N 61.4, E 5.9	Az	151.4	155.0	160.1	164.9	168.5	171.9	175.3	176.5	178.8	181.3	187.6	192.4
	El	17.3	18.0	18.9	19.6	19.9	20.2	20.4	20.4	20.5	20.5	20.2	19.9
	Sk	-5.8	-4.2	-1.9	0.4	-5.5	-3.9	-2.2	-1.7	-0.6	8.1	3.6	5.9
Fredrikstad N 59.2, E 11.0	Az	156.5	160.2	165.5	170.5	174.2	177.7	181.2	182.3	184.7	187.2	193.7	198.5
	El	20.5	21.2	21.9	22.4	22.6	22.8	22.8	22.8	22.7	22.6	22.0	21.4
	Sk	-4.3	-2.5	0.2	2.6	-3.0	-1.2	0.6	1.2	2.4	11.2	7.0	9.3
Gjøvik N 60.8, E 10.7	Az	156.5	160.1	165.4	170.3	173.9	177.4	180.8	182.0	184.2	186.8	193.1	197.9
	El	18.9	19.5	20.3	20.7	20.9	21.1	21.1	21.1	21.0	20.9	20.4	19.8
	Sk	-3.7	-2.0	0.4	2.8	-3.0	-1.3	0.4	1.0	2.1	10.8	6.4	8.6
Halden N 59.1, E 11.5	Az	157.0	160.7	166.1	171.1	174.8	178.3	181.8	182.9	185.2	187.8	194.3	199.1
	El	20.7	21.4	22.1	22.6	22.8	22.9	22.9	22.9	22.8	22.6	22.1	21.4
	Sk	-4.1	-2.3	0.4	2.9	-2.7	-0.9	0.9	1.5	2.7	11.5	7.3	9.7
Hamar N 60.8, E 11.1	Az	156.9	160.6	165.9	170.7	174.4	177.8	181.3	182.4	184.7	187.2	193.6	198.3
	El	19.0	19.6	20.3	20.8	21.0	21.1	21.1	21.1	21.0	20.9	20.4	19.8
	Sk	-3.5	-1.8	0.7	3.0	-2.7	-1.1	0.6	1.2	2.3	11.0	6.6	8.8
Haugesund N 59.4, E 5.3	Az	150.2	153.9	159.1	164.0	167.6	171.1	174.5	175.7	178.0	180.6	187.1	191.9
	El	19.0	19.8	20.8	21.5	22.0	22.3	22.5	22.5	22.6	22.6	22.4	22.0
	Sk	-7.1	-5.5	-3.0	-0.6	-6.3	-4.5	-2.8	-2.2	-1.0	7.8	3.6	6.0
Kristiansand N 58.1, E 8.0	Az	152.9	156.6	161.9	166.9	170.6	174.1	177.6	178.8	181.2	183.8	190.3	195.2
	El	20.9	21.7	22.6	23.2	23.6	23.8	23.9	24.0	24.0	23.9	23.5	23.0
	Sk	-6.4	-4.6	-1.9	0.6	-5.0	-3.1	-1.2	-0.6	0.6	9.5	5.4	8.0
Larvik N 59.1, E 10.0	Az	155.3	159.0	164.4	169.3	173.0	176.5	180.0	181.2	183.5	186.1	192.5	197.3
	El	20.4	21.1	21.9	22.4	22.7	22.8	22.9	22.9	22.8	22.7	22.3	21.7
	Sk	-4.9	-3.1	-0.5	2.0	-3.6	-1.8	0.0	0.6	1.8	10.6	6.4	8.8
Moss N 59.5, E 10.7	Az	156.2	159.9	165.2	170.2	173.9	177.3	180.8	182.0	184.3	186.8	193.3	198.1
	El	20.2	20.8	21.6	22.1	22.3	22.4	22.5	22.5	22.4	22.3	21.8	21.1
	Sk	-4.3	-2.5	0.1	2.5	-3.1	-1.4	0.4	1.0	2.2	11.0	6.7	9.1
Oslo N 60.0, E 10.8	Az	156.4	160.1	165.4	170.3	174.0	177.5	180.9	182.1	184.4	186.9	193.3	198.1
	El	19.7	20.3	21.1	21.6	21.8	21.9	21.9	21.9	21.9	21.7	21.2	20.6
	Sk	-4.0	-2.3	0.3	2.7	-3.0	-1.3	0.5	1.0	2.2	11.0	6.6	8.9
Porsgrunn/Skien N 59.1, E 9.7	Az	155.0	158.7	164.0	169.0	172.7	176.2	179.7	180.8	183.2	185.7	192.2	197.0
	El	20.3	21.0	21.8	22.4	22.7	22.8	22.9	22.9	22.9	22.8	22.3	21.7
	Sk	-5.0	-3.3	-0.6	1.9	-3.8	-2.0	-0.2	0.4	1.6	10.4	6.2	8.6
Ringsaker N 61.0, E 10.8	Az	156.6	160.3	165.6	170.4	174.1	177.5	180.9	182.1	184.3	186.9	193.2	197.9
	El	18.7	19.4	20.1	20.5	20.7	20.9	20.9	20.9	20.8	20.7	20.2	19.6
	Sk	-3.6	-1.9	0.6	2.9	-2.9	-1.2	0.4	1.0	2.1	10.8	6.4	8.6
Sandefjord N 59.4, E 10.2	Az	155.6	159.3	164.6	169.5	173.3	176.7	180.2	181.4	183.7	186.3	192.8	197.6
	El	20.4	21.1	21.9	22.4	22.7	22.9	22.9	22.9	22.8	22.7	22.2	21.6
	Sk	-4.8	-3.0	-0.3	2.2	-3.5	-1.7	0.1	0.7	1.9	10.7	6.5	8.9
Skien N 59.2, E 9.6	Az	154.9	158.6	163.9	168.9	172.6	176.0	179.5	180.7	183.0	185.6	192.1	196.9
	El	20.2	20.9	21.7	22.3	22.6	22.7	22.8	22.8	22.8	22.7	22.2	21.6
	Sk	-5.0	-3.3	-0.7	1.8	-3.8	-2.0	-0.2	0.4	1.6	10.4	6.1	8.6
Stavanger N 59.0, E 5.7	Az	150.6	154.2	159.5	164.4	168.0	171.5	175.0	176.2	178.5	181.1	187.6	192.4
	El	19.4	20.3	21.3	22.0	22.4	22.7	22.9	22.9	23.0	23.0	22.8	22.4
	Sk	-7.2	-5.5	-2.9	-0.5	-6.1	-4.4	-2.6	-2.0	-0.8	8.0	3.9	6.4
Stjørdal N 63.5, E 11.2	Az	157.5	161.1	166.3	171.1	174.6	178.0	181.3	182.5	184.7	187.1	193.4	198.0
	El	16.4	16.9	17.6	18.0	18.1	18.2	18.2	18.2	18.2	18.1	17.6	17.1
	Sk	-2.3	-0.8	1.4	3.5	-2.4	-0.9	0.6	1.1	2.1	10.7	5.9	7.9
Tønsberg N 59.3, E 10.4	Az	155.8	159.5	164.9	169.8	173.5	177.0	180.5	181.6	184.0	186.5	193.0	197.8
	El	20.3	21.0	21.7	22.3	22.5	22.6	22.7	22.7	22.6	22.5	22.0	21.4
	Sk	-4.6	-2.8	-0.2	2.3	-3.3	-1.5	0.2	0.8	2.0	10.8	6.6	9.0
Trondheim N 63.4, E 10.4	Az	156.7	160.3	165.4	170.2	173.7	177.1	180.5	181.6	183.8	186.3	192.5	197.1
	El	16.4	16.9	17.6	18.0	18.2	18.3	18.3	18.3	18.3	18.2	17.8	17.3
	Sk	-2.7	-1.2	1.0	3.1	-2.8	-1.3	0.2	0.7	1.7	10.3	5.6	7.6

Spain

E=East Longitude W=West Longitude N= North Latitude S= South Latitude Az=Azimuth El=Elevation Sk=Skew

		Türksat	ASTRA 5	ASTRA 2	ASTRA 3	ASTRA 1	Eutelsat 16	Eutelsat Hotbird 13	Eutelsat 9	SES 5 / ASTRA 4	Thor / Intelsat 10 02	Eutelsat 5W	Hispasat
		42.0° East	31.5° East	28.2° East	23.5° East	19.2° East	16.0° East	13.0° East	9.0° East	4.8° East	0.8° West	5.0° West	30.0° West
Albacete N 39.0, W 1.8	Az	123.3	133.8	137.5	143.1	148.6	153.0	157.2	163.1	169.6	178.7	185.1	220.4
	El	26.3	33.2	35.2	37.8	39.8	41.2	42.3	43.5	44.3	44.8	44.7	36.2
	Sk	-40.5	-27.1	-24.7	-20.8	-16.9	-20.7	-17.5	-13.0	-8.1	-1.0	3.9	30.3
Alicante N 38.4, W 0.5	Az	124.1	134.8	138.6	144.4	150.0	154.5	158.9	164.9	171.5	180.8	187.2	222.3
	El	27.6	34.5	36.4	39.0	41.0	42.3	43.3	44.4	45.2	45.5	45.3	36.0
	Sk	-40.4	-26.8	-24.2	-20.2	-16.0	-19.7	-16.4	-11.8	-6.7	0.6	5.7	31.9
Almeria N 36.9, W 2.5	Az	121.4	131.7	135.3	140.9	146.5	150.9	155.2	161.3	168.0	177.5	184.2	220.9
	El	27.0	34.4	36.5	39.2	41.5	43.0	44.2	45.5	46.5	47.2	47.1	38.4
	Sk	-43.0	-29.7	-27.2	-23.3	-19.2	-22.9	-19.6	-14.9	-9.6	-2.0	3.3	31.6
Barcelona N 41.4, E 2.2	Az	128.4	139.7	143.6	149.5	155.2	159.6	163.9	169.8	176.1	184.8	190.8	223.6
	El	27.5	33.6	35.3	37.4	39.1	40.1	40.9	41.7	42.1	42.1	41.6	32.0
	Sk	-36.0	-22.0	-19.4	-15.4	-11.4	-15.1	-12.0	-7.7	-3.0	3.6	8.1	31.2
Bilbao N 43.3, W 2.9	Az	124.5	135.1	138.7	144.1	149.4	153.5	157.4	162.9	168.9	177.2	183.1	216.7
	El	23.0	29.3	31.1	33.4	35.3	36.5	37.5	38.6	39.5	40.0	40.0	33.1
	Sk	-36.8	-23.9	-21.7	-18.3	-14.8	-19.0	-16.2	-12.3	-8.1	-2.0	2.2	25.8
Cartagena N 37.6, W 1.0	Az	123.2	133.8	137.5	143.2	148.9	153.4	157.8	163.9	170.6	180.0	186.5	222.3
	El	27.7	34.8	36.8	39.4	41.5	42.9	44.0	45.2	46.0	46.4	46.2	36.9
	Sk	-41.5	-27.9	-25.4	-21.3	-17.2	-20.8	-17.4	-12.7	-7.5	0.0	5.2	32.2
Cordoba N 37.8, W 4.8	Az	119.9	129.8	133.3	138.7	144.0	148.2	152.4	158.2	164.6	173.8	180.3	217.5
	El	24.9	32.2	34.3	37.2	39.5	41.1	42.4	43.9	45.0	46.0	46.2	38.9
	Sk	-43.2	-30.4	-28.1	-24.4	-20.7	-24.6	-21.5	-17.1	-12.1	-4.9	0.3	28.8
Gijon N 43.5, W 5.7	Az	122.1	132.2	135.7	140.9	146.0	150.0	153.8	159.1	164.9	173.2	179.0	213.3
	El	21.1	27.6	29.5	31.9	33.9	35.3	36.4	37.7	38.7	39.6	39.8	34.2
	Sk	-37.9	-25.5	-23.4	-20.2	-16.9	-21.3	-18.7	-15.0	-10.9	-4.9	-0.7	23.4
Granada N 37.2, W 3.6	Az	120.6	130.7	134.3	139.8	145.2	149.5	153.8	159.7	166.3	175.7	182.3	219.4
	El	26.1	33.4	35.5	38.4	40.7	42.2	43.5	44.9	46.0	46.8	46.8	38.7
	Sk	-43.3	-30.2	-27.8	-24.0	-20.1	-23.8	-20.6	-16.0	-10.9	-3.4	1.8	30.4
Hospitalet de Llobregat N 41.4, E 2.1	Az	128.3	139.6	143.5	149.4	155.1	159.5	163.8	169.6	175.9	184.7	190.7	223.5
	El	27.4	33.6	35.3	37.4	39.1	40.1	40.9	41.6	42.1	42.1	41.6	32.1
	Sk	-36.0	-22.1	-19.5	-15.5	-11.4	-15.2	-12.1	-7.8	-3.1	3.5	8.0	31.1
Ibiza N 38.9, E 1.4	Az	126.2	137.3	141.2	147.1	152.9	157.5	161.9	168.0	174.6	183.8	190.1	224.2
	El	28.6	35.2	37.1	39.4	41.3	42.5	43.4	44.3	44.8	44.9	44.5	34.5
	Sk	-38.9	-24.9	-22.2	-18.0	-13.8	-17.4	-14.0	-9.3	-4.2	3.0	7.9	32.9
Las Palmas N 28.1, W 15.4	Az	106.8	113.8	116.3	120.3	124.3	127.7	131.1	136.1	142.0	151.4	158.7	208.9
	El	20.2	29.5	32.4	36.4	39.9	42.4	44.7	47.6	50.3	53.5	55.2	53.4
	Sk	-57.6	-46.8	-45.3	-42.6	-39.8	-44.3	-41.7	-37.7	-32.9	-25.0	-18.7	25.3
Madrid N 40.4, W 3.7	Az	123.3	132.6	136.2	141.6	146.9	151.1	155.2	160.8	167.0	175.8	182.0	217.3
	El	24.2	31.0	33.0	35.6	37.7	39.1	40.2	41.5	42.5	43.2	43.3	36.0
	Sk	-40.1	-27.1	-24.8	-21.2	-17.6	-21.6	-18.7	-14.5	-9.9	-3.2	1.5	27.5
Malaga N 36.7, W 4.4	Az	119.6	129.5	133.1	138.5	143.8	148.1	152.3	158.3	164.8	174.3	181.0	218.7
	El	25.7	33.2	35.4	38.3	40.7	42.3	43.6	45.1	46.3	47.3	47.4	39.6
	Sk	-44.2	-31.2	-28.9	-25.1	-21.2	-25.1	-21.9	-17.3	-12.1	-4.6	0.8	30.1
Palma de Mallorca N 39.6, E 2.7	Az	127.9	139.2	143.2	149.2	155.1	159.7	164.1	170.2	176.7	185.8	192.0	225.2
	El	29.0	35.4	37.1	39.4	41.1	42.1	42.9	43.7	44.1	44.0	43.5	33.1
	Sk	-37.4	-23.2	-20.5	-16.2	-12.0	-15.5	-12.2	-7.6	-2.5	4.5	9.2	33.2
Salamanca N 41.0, W 5.7	Az	120.8	130.8	134.3	139.6	144.7	148.8	152.7	158.2	164.2	172.9	178.9	214.5
	El	22.5	29.4	31.4	34.0	36.2	37.7	38.9	40.3	41.4	42.4	42.6	36.5
	Sk	-40.4	-27.8	-25.7	-22.3	-18.8	-23.0	-20.3	-16.3	-11.8	-5.4	-0.8	25.3
Santa Cruz de la Palma N 28.7, W 17.8	Az	105.6	112.4	114.9	118.7	122.5	125.7	128.9	133.6	139.1	147.8	154.7	204.2
	El	17.9	27.2	30.0	34.0	37.6	40.2	42.5	45.4	48.3	51.7	53.7	53.9
	Sk	-57.7	-47.2	-45.7	-43.3	-40.7	-45.5	-43.1	-39.5	-35.1	-27.8	-22.0	21.1
Santa Cruz de Tenerife N 28.5, W 16.3	Az	106.4	113.4	115.9	119.8	123.8	127.1	130.4	135.3	141.0	150.2	157.3	207.1
	El	19.3	28.5	31.4	35.4	38.9	41.5	43.8	46.7	49.4	52.7	54.5	53.5
	Sk	-57.5	-46.8	-45.2	-42.7	-39.9	-44.5	-42.0	-38.2	-33.6	-25.9	-19.8	23.6
Santander N 43.5, W 3.9	Az	123.7	134.1	137.7	143.0	148.2	152.3	156.2	161.6	167.5	175.8	181.6	215.4
	El	22.3	28.6	30.4	32.8	34.7	36.0	37.0	38.2	39.1	39.7	39.8	33.4
	Sk	-37.1	-24.4	-22.3	-18.9	-15.5	-19.7	-17.0	-13.2	-9.1	-3.1	1.2	24.9
Sevilla N 37.4, W 6.0	Az	118.7	128.4	131.8	137.0	142.2	146.4	150.5	156.2	162.6	171.8	178.4	216.2
	El	24.2	31.7	33.9	36.8	39.2	40.9	42.3	43.9	45.2	46.3	46.6	39.9
	Sk	-44.2	-31.5	-29.3	-25.8	-22.1	-26.1	-23.1	-18.7	-13.8	-6.5	-1.3	28.0
Valencia N 39.3, W 0.7	Az	124.5	135.2	138.9	144.6	150.3	154.7	159.0	164.9	171.4	180.5	186.8	221.5
	El	26.9	33.7	35.6	38.1	40.0	41.3	42.3	43.4	44.2	44.5	44.3	35.4
	Sk	-39.6	-26.1	-23.6	-19.6	-15.6	-19.4	-16.1	-11.6	-6.7	0.4	5.2	30.9
Valladolid N 41.6, W 4.7	Az	122.0	132.2	135.7	141.1	146.3	150.4	154.3	159.8	165.9	174.4	180.5	215.5
	El	22.8	29.6	31.5	34.0	36.1	37.5	38.7	39.9	41.0	41.8	41.9	35.5
	Sk	-39.3	-26.6	-24.5	-21.0	-17.5	-21.7	-18.9	-14.9	-10.5	-4.2	0.3	25.7
Vigo N 42.2, W 8.7	Az	118.8	128.5	131.8	136.9	141.8	145.6	149.4	154.6	160.3	168.6	174.5	210.1
	El	19.8	26.7	28.7	31.4	33.7	35.2	36.5	38.1	39.4	40.6	41.1	36.7
	Sk	-40.5	-28.4	-26.5	-23.4	-20.3	-24.7	-22.2	-18.5	-14.4	-8.4	-4.1	21.8
Zaragoza N 41.6, W 1.0	Az	125.5	136.2	139.9	145.5	151.0	155.3	159.4	165.1	171.3	180.0	186.0	219.9
	El	25.3	31.7	33.5	35.8	37.7	38.9	39.9	40.9	41.6	41.9	41.8	33.6
	Sk	-37.5	-24.2	-21.8	-18.0	-14.3	-18.2	-15.2	-11.1	-6.5	0.0	4.5	28.6

Sweden

E=East Longitude W=West Longitude N= North Latitude S= South Latitude Az=Azimuth El=Elevation Sk=Skew

		ASTRA 5	ASTRA 2	ASTRA 3	ASTRA 1	Eutelsat 16	Eutelsat Hotbird 13	Eutelsat 10	Eutelsat 9	Eutelsat 7	SES 5 / ASTRA 4	Thor / Intelsat 10 02	Eutelsat 5W
		31.5° East	28.2° East	23.5° East	19.2° East	16.0° East	13.0° East	10.0° East	9.0° East	7.0° East	4.8° East	0.8° West	5.0° West
Arvidsjaur N 65.6, E 19.1	Az	166.4	170.0	175.2	179.9	183.4	186.7	190.0	191.1	193.3	195.6	201.9	206.2
	El	15.4	15.7	16.0	16.0	16.0	15.9	15.7	15.6	15.4	15.2	14.4	13.7
	Sk	1.4	2.9	5.0	7.0	1.4	2.8	4.1	4.6	5.4	6.4	8.9	10.5
Borås N 57.7, E 12.9	Az	158.3	162.1	167.5	172.6	176.3	179.9	183.4	184.6	187.0	189.6	196.3	200.9
	El	22.4	23.0	23.7	24.2	24.3	24.4	24.3	24.3	24.2	24.0	23.3	22.5
	Sk	-4.4	-2.5	0.4	3.0	-2.0	-0.1	1.8	2.5	3.7	5.1	8.6	11.0
Borlänge N 60.5, E 15.4	Az	161.7	165.4	170.7	175.6	179.3	182.8	186.2	187.3	189.6	192.1	198.7	203.1
	El	20.1	20.6	21.1	21.3	21.4	21.4	21.3	21.2	21.0	20.8	20.0	19.3
	Sk	-1.9	-0.1	2.4	4.9	-0.3	1.4	3.1	3.6	4.7	5.9	9.1	11.2
Falkenberg N 56.9, E 12.5	Az	157.7	161.5	166.9	172.0	175.8	179.4	183.0	184.2	186.6	189.2	196.0	200.6
	El	23.1	23.8	24.5	25.0	25.2	25.2	25.2	25.2	25.1	24.9	24.1	23.4
	Sk	-5.0	-3.0	-0.1	2.7	-2.3	-0.3	1.6	2.3	3.6	5.0	8.7	11.1
Gävle N 60.7, E 17.1	Az	163.6	167.3	172.7	177.6	181.3	184.7	188.1	189.3	191.5	194.0	200.6	205.0
	El	20.1	20.6	21.0	21.2	21.2	21.1	20.9	20.9	20.7	20.4	19.5	18.7
	Sk	-0.9	0.8	3.4	5.8	0.6	2.3	4.0	4.5	5.6	6.8	9.9	11.9
Göteborg N 57.8, E 12.0	Az	157.3	161.1	166.5	171.5	175.3	178.8	182.4	183.5	185.9	188.5	195.3	199.9
	El	22.1	22.8	23.5	24.0	24.2	24.3	24.3	24.2	24.1	24.0	23.3	22.6
	Sk	-4.9	-3.0	-0.2	2.5	-2.5	-0.6	1.3	1.9	3.1	4.5	8.1	10.4
Helsingborg N 56.1, E 12.8	Az	157.8	161.6	167.2	172.3	176.2	179.8	183.4	184.6	187.0	189.6	196.5	201.2
	El	23.9	24.6	25.4	25.8	26.0	26.1	26.0	26.0	25.9	25.7	24.9	24.1
	Sk	-5.2	-3.1	-0.1	2.7	-2.2	-0.1	1.9	2.6	3.9	5.3	9.1	11.6
Jönköping N 57.8, E 14.2	Az	159.8	163.6	169.1	174.1	177.9	181.4	185.0	186.1	188.5	191.1	197.8	202.4
	El	22.6	23.1	23.8	24.1	24.3	24.3	24.2	24.1	24.0	23.8	22.9	22.2
	Sk	-3.6	-1.7	1.2	3.9	-1.1	0.8	2.6	3.3	4.5	5.9	9.4	11.7
Kalmar N 56.7, E 16.3	Az	162.0	165.9	171.4	176.5	180.4	184.0	187.5	188.7	191.1	193.7	200.2	205.0
	El	24.1	24.6	25.1	25.4	25.5	25.4	25.2	25.1	24.9	24.7	23.7	22.8
	Sk	-2.3	-0.2	2.8	5.6	0.2	2.2	4.1	4.8	6.1	15.0	10.9	13.4
Karlstad N 59.4, E 13.5	Az	159.3	163.1	168.4	173.4	177.1	180.6	184.1	185.2	187.5	190.1	196.7	201.2
	El	20.8	21.4	22.0	22.4	22.5	22.6	22.5	22.5	22.3	22.2	21.4	20.7
	Sk	-3.4	-1.5	1.1	3.6	-1.5	0.3	2.1	2.7	3.8	5.1	8.4	10.6
Kristianstad N 56.0, E 14.2	Az	159.4	163.3	168.8	174.0	177.8	181.5	185.1	186.3	188.7	191.3	198.2	202.8
	El	24.4	25.0	25.7	26.0	26.2	26.2	26.1	26.0	25.9	25.6	24.8	23.9
	Sk	-4.3	-2.3	0.8	3.6	-1.2	0.8	2.8	3.5	4.8	6.3	10.0	12.5
Lidköping N 58.5, E 13.2	Az	158.8	162.6	168.0	173.0	176.7	180.2	183.8	184.9	187.3	189.8	196.5	201.1
	El	21.7	22.3	22.9	23.3	23.5	23.5	23.5	23.4	23.3	23.1	22.4	21.7
	Sk	-3.9	-2.0	0.8	3.3	-1.7	0.1	2.0	2.6	3.8	5.1	8.6	10.8
Linköping N 58.4, E 15.6	Az	161.5	165.3	170.8	175.8	179.5	183.1	186.6	187.7	190.1	192.6	199.3	203.8
	El	22.2	22.7	23.3	23.6	23.6	23.6	23.5	23.4	23.2	23.0	22.1	21.3
	Sk	-2.6	-0.6	2.2	4.8	-0.3	1.6	3.4	4.0	5.3	6.6	10.0	12.2
Malmö N 55.6, E 13.0	Az	157.9	161.8	167.3	172.5	176.4	180.0	183.6	184.8	187.3	189.9	196.8	201.5
	El	24.5	25.2	25.9	26.4	26.6	26.6	26.6	26.5	26.4	26.2	25.4	24.6
	Sk	-5.3	-3.2	-0.1	2.8	-2.1	0.0	2.1	2.7	4.1	5.6	9.4	12.0
Norrköping N 58.6, E 16.2	Az	162.2	166.0	171.5	176.5	180.2	183.8	187.3	188.4	190.7	193.3	199.9	204.4
	El	22.1	22.6	23.1	23.4	23.4	23.4	23.2	23.1	22.9	22.7	21.8	20.9
	Sk	-2.2	-0.2	2.6	5.2	0.1	2.0	3.8	4.4	5.6	6.9	10.2	12.5
Stockholm N 59.3, E 18.1	Az	164.5	168.3	173.7	178.7	182.4	185.9	189.4	190.6	192.9	195.4	201.9	206.4
	El	21.7	22.1	22.5	22.7	22.7	22.5	22.3	22.2	22.0	21.7	20.7	19.8
	Sk	-0.8	1.1	3.8	6.4	1.3	3.0	4.8	5.4	6.5	7.8	11.0	13.1
Sundsväl N 62.4, E 17.2	Az	164.0	167.6	172.9	177.7	181.4	184.7	188.1	189.2	191.5	193.9	200.4	204.7
	El	18.4	18.8	19.2	19.4	19.4	19.3	19.2	19.1	18.9	18.7	17.8	17.1
	Sk	-0.4	1.3	3.7	6.0	0.6	2.2	3.8	4.3	5.3	6.4	9.3	11.2
Umeå N 63.8, E 21.2	Az	168.6	172.2	177.4	182.2	185.8	189.1	192.4	193.6	195.8	198.2	204.5	208.7
	El	17.5	17.7	17.9	17.9	17.8	17.6	17.4	17.3	17.0	16.7	15.8	14.9
	Sk	2.0	3.6	5.9	8.0	2.6	4.0	5.5	5.9	6.9	7.9	10.5	12.3
Uppsala N 59.9, E 17.6	Az	164.0	167.8	173.2	178.2	181.9	185.3	188.8	189.9	192.2	194.7	201.3	205.7
	El	21.0	21.4	21.9	22.0	22.0	21.9	21.7	21.6	21.4	21.2	20.2	19.4
	Sk	-0.9	0.9	3.6	6.1	0.9	2.7	4.4	5.0	6.1	7.3	10.5	12.6
Visby (Gotland) N 57.6, E 18.3	Az	164.5	168.3	173.9	178.9	182.7	186.3	189.8	191.0	193.3	195.9	202.5	207.0
	El	23.5	23.9	24.3	24.5	24.5	24.3	24.1	24.0	23.7	23.4	22.3	21.4
	Sk	-1.3	0.8	3.7	6.4	1.5	3.4	5.2	5.9	7.1	8.4	11.9	14.1
Västervik N 57.7, E 16.6	Az	162.5	166.4	171.9	176.9	180.7	184.3	187.8	189.0	191.3	193.9	200.6	205.1
	El	23.1	23.6	24.1	24.3	24.4	24.3	24.1	24.0	23.8	23.6	22.6	21.7
	Sk	-2.2	-0.2	2.7	5.4	0.4	2.3	4.2	4.8	6.0	7.4	10.8	13.1
Växjö N 56.9, E 14.6	Az	160.1	163.9	169.4	174.5	178.3	181.9	185.5	186.7	189.1	191.7	198.4	203.0
	El	23.5	24.1	24.8	25.1	25.2	25.2	25.1	25.0	24.9	24.7	23.8	23.0
	Sk	-3.7	-1.7	1.2	4.0	-0.9	1.0	3.0	3.6	4.9	6.3	9.9	12.3
Örebro N 59.3, E 15.1	Az	161.1	164.9	170.3	175.2	179.0	182.4	185.9	187.1	189.4	191.9	198.6	203.1
	El	21.2	21.7	22.3	22.6	22.7	22.7	22.5	22.5	22.3	22.1	21.3	20.5
	Sk	-2.5	-0.7	2.0	4.6	-0.5	1.3	3.0	3.6	4.8	6.1	9.4	11.5
Östersund N 63.6, E 14.7	Az	161.4	165.0	170.2	175.0	178.6	181.9	185.2	186.4	188.6	191.0	197.4	201.8
	El	16.9	17.3	17.8	18.0	18.1	18.1	18.0	18.0	17.9	17.7	17.0	16.4
	Sk	-1.2	0.4	2.7	4.8	-0.7	0.8	2.3	2.8	3.8	4.9	7.7	9.5

Switzerland

E=East Longitude W=West Longitude N= North Latitude S= South Latitude Az=Azimuth El=Elevation Sk=Skew

	Türksat	ASTRA 5	ASTRA 2	ASTRA 3	ASTRA 1	Eutelsat 16	Eutelsat Holbird 13	Eutelsat 9	SES 5 / ASTRA 4	Thor / Intelsat 10 02	Eutelsat 5W	Hispasat
	42.0° East	31.5° East	28.2° East	23.5° East	19.2° East	16.0° East	13.0° East	9.0° East	4.8° East	0.8° West	5.0° West	30.0° West
Basel N 47.6, E 7.6	Az	137.2	149.0	153.0	158.9	164.5	168.7	172.7	178.1	183.8	191.6	196.8
	El	26.0	30.6	31.8	33.2	34.2	34.7	35.1	35.29	35.2	34.7	33.9
	Sk	-27.3	-13.3	-10.8	-7.0	-3.4	-7.6	-4.9	-1.28	2.6	7.8	11.3
Bern N 47.0, E 7.4	Az	136.7	148.6	152.6	158.5	164.1	168.3	172.4	177.81	183.6	191.4	196.7
	El	26.4	31.1	32.3	33.7	34.7	35.3	35.7	35.94	35.9	35.3	34.6
	Sk	-27.9	-13.9	-11.3	-7.5	-3.8	-7.9	-5.2	-1.49	2.4	7.8	11.3
Biel N 46.5, E 8.2	Az	137.3	149.3	153.4	159.3	165.0	169.3	173.4	178.9	184.7	192.6	197.9
	El	27.2	31.8	33.0	34.4	35.4	36.0	36.3	36.51	36.4	35.8	35.0
	Sk	-27.8	-13.6	-11.0	-7.1	-3.3	-7.3	-4.5	-0.76	3.2	8.6	12.2
Genf N 46.2, E 6.2	Az	135.0	146.8	150.8	156.7	162.3	166.5	170.6	176.12	181.9	189.9	195.3
	El	26.4	31.3	32.6	34.2	35.3	36.0	36.4	36.78	36.8	36.4	35.7
	Sk	-29.3	-15.3	-12.8	-8.9	-5.2	-9.3	-6.5	-2.68	1.3	6.9	10.6
Köniz N 46.9, E 7.4	Az	136.6	148.5	152.5	158.4	164.0	168.3	172.4	177.81	183.6	191.4	196.8
	El	26.4	31.2	32.4	33.8	34.9	35.4	35.8	36.05	36.0	35.5	34.7
	Sk	-28.0	-13.9	-11.4	-7.6	-3.8	-8.0	-5.2	-1.5	2.4	7.8	11.4
Lausanne N 46.5, E 6.7	Az	135.7	147.5	151.5	157.4	163.0	167.3	171.4	176.83	182.6	190.6	195.9
	El	26.4	31.2	32.5	34.0	35.1	35.7	36.2	36.47	36.5	36.0	35.3
	Sk	-28.7	-14.7	-12.2	-8.3	-4.6	-8.7	-6.0	-2.18	1.8	7.3	10.9
Locarno N 46.2, E 8.8	Az	137.8	149.9	154.0	160.0	165.7	170.1	174.2	179.72	185.5	193.5	198.8
	El	27.7	32.3	33.5	34.9	35.9	36.4	36.7	36.85	36.7	36.0	35.1
	Sk	-27.7	-13.3	-10.7	-6.7	-2.8	-6.9	-4.0	-0.19	3.8	9.3	12.9
Luzern N 47.0, E 7.9	Az	137.2	149.2	153.2	159.1	164.7	169.0	173.0	178.5	184.2	191.8	197.4
	El	26.6	31.3	32.4	33.8	34.8	35.4	35.7	36.0	35.9	35.3	34.5
	Sk	-27.6	-13.0	-10.4	-6.6	-2.9	-7.5	-4.7	-1.0	10.4	8.0	11.8
Sankt Gallen N 47.4, E 9.4	Az	139.0	151.1	155.2	161.2	166.8	171.1	175.1	180.54	186.2	194.0	199.2
	El	27.0	31.4	32.5	33.8	34.7	35.2	35.4	35.53	35.3	34.6	33.7
	Sk	-26.4	-12.1	-9.5	-5.6	-1.9	-6.0	-3.3	0.37	4.2	9.4	12.9
Thun N 46.8, E 7.6	Az	136.8	148.7	152.7	158.7	164.3	168.6	172.6	178.08	183.8	191.7	197.1
	El	26.6	31.3	32.5	34.0	35.0	35.6	35.9	36.17	36.1	35.5	34.8
	Sk	-28.0	-13.8	-11.3	-7.4	-3.7	-7.8	-5.1	-1.31	2.6	8.0	11.6
Winterthur N 47.5, E 8.8	Az	138.4	150.4	154.5	160.4	166.0	170.3	174.3	179.73	185.4	193.2	198.4
	El	26.7	31.1	32.2	33.6	34.5	35.0	35.3	35.42	35.3	34.6	33.8
	Sk	-26.7	-12.5	-9.9	-6.1	-2.4	-6.6	-3.8	-0.18	3.7	8.9	12.3
Zürich N 47.4, E 8.6	Az	138.2	150.2	154.2	160.1	165.7	170.0	174.0	179.46	185.2	192.9	198.2
	El	26.6	31.1	32.3	33.6	34.6	35.1	35.4	35.53	35.4	34.7	33.9
	Sk	-26.9	-12.7	-10.1	-6.3	-2.6	-6.8	-4.0	-0.37	3.5	8.7	12.2